

EM260

ZigBee/802.15.4 Network Processor

- *Integrated 2.4GHz, IEEE 802.15.4-compliant transceiver:*
 - Robust RX filtering allows co-existence with IEEE 802.11g and Bluetooth devices
 - - 97.5dBm RX sensitivity (1% PER, 20byte packet)
 - + 3dBm nominal output power
 - Increased radio performance mode (boost mode) gives - 98.5dBm sensitivity and + 5dBm transmit power
 - Integrated VCO and loop filter
 - Secondary TX-only RF port for applications requiring external PA.
- *Integrated IEEE 802.15.4 PHY and MAC*
- *Ember ZigBee-compliant stack running on the dedicated network processor*
- *Controlled by the Host using the EmberZNet Serial Protocol (EZSP)*
 - Standard Serial Interface (allows for connection to a variety of Host microcontrollers)
- *Non-intrusive debug interface (SIF)*
- *Integrated hardware and software support for InSight Development Environment*
- *Dedicated peripherals and integrated memory*
- *Provides integrated RC oscillator for low power operation*
- *Three sleep modes:*
 - Processor idle (automatic)
 - Deep sleep—1.0µA
 - Power down—1.0µA
- *Watchdog timer and power-on-reset circuitry*
- *Integrated AES encryption accelerator*
- *Integrated 1.8V voltage regulator*

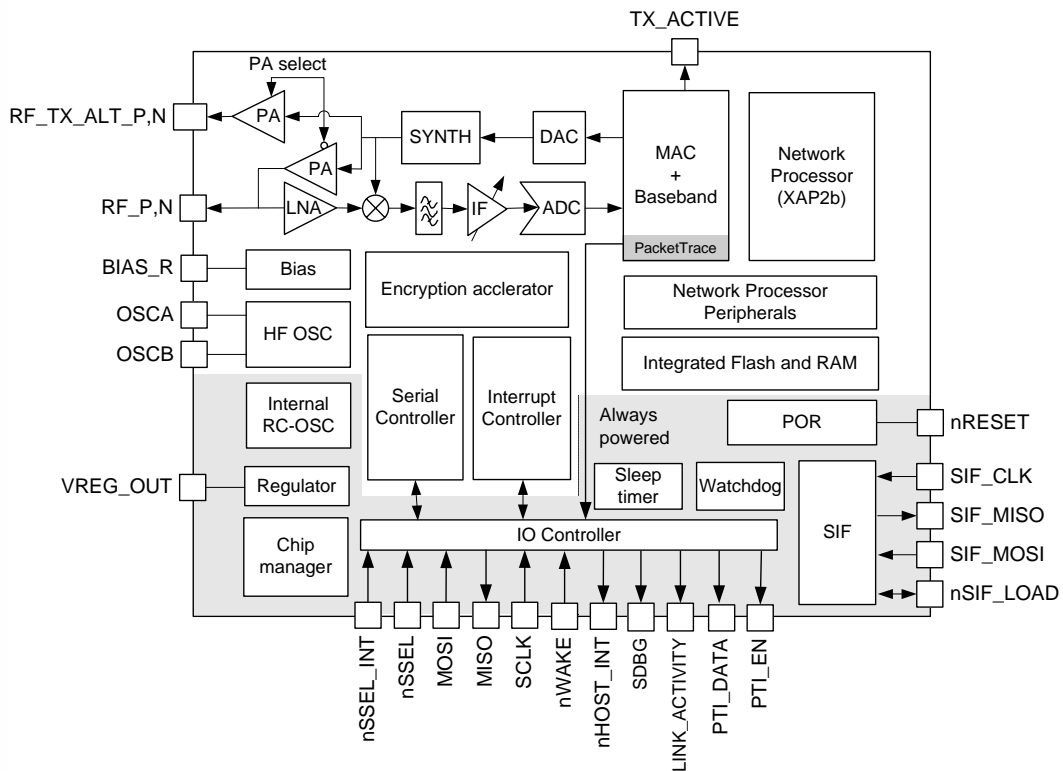

General Description

The EM260 integrates a 2.4GHz, IEEE 802.15.4-compliant transceiver with a 16-bit network processor (XAP2b core) to run EmberZNet, the Ember ZigBee-compliant network stack. The EM260 exposes access to the EmberZNet API across a standard SPI module, allowing application development on a Host processor. This means that the EM260 can be viewed as a ZigBee peripheral connected over a SPI. The XAP2b microprocessor is a power-optimized core integrated in the EM260. It contains integrated Flash and RAM memory along with an optimized peripheral set to enhance the operation of the network stack.

The transceiver utilizes an efficient architecture that exceeds the dynamic range requirements imposed by the IEEE 802.15.4-2003 standard by over 15dB. The integrated receive channel filtering allows for co-existence with other communication standards in the 2.4GHz spectrum such as IEEE 802.11g and Bluetooth. The integrated regulator, VCO, loop filter, and power amplifier keep the external component count low. An optional high-performance radio mode (boost mode) is software selectable to boost dynamic range by a further 3dB.

The EM260 contains embedded Flash and integrated RAM for program and data storage. By employing an effective wear-leveling algorithm, the stack optimizes the lifetime of the embedded Flash, and affords the application the ability to configure stack and application tokens within the EM260.

To maintain the strict timing requirements imposed by ZigBee and the IEEE 802.15.4-2003 standard, the EM260 integrates a number of MAC functions into the hardware. The MAC hardware handles automatic ACK transmission and reception, automatic backoff delay, and clear channel assessment for transmission, as well as automatic filtering of received packets. In addition, the EM260 allows for true MAC level debugging by integrating the Packet Trace Interface.

An integrated voltage regulator, power-on-reset circuitry, sleep timer, and low-power sleep modes are available. The deep sleep and power down modes draws less than 1 μ A, allowing products to achieve long battery life.

Finally, the EM260 utilizes the non-intrusive SIF module for powerful software debugging and programming of the network processor.

Target applications for the EM260 include:

- *Building automation and control*
- *Home automation and control*
- *Home entertainment control*
- *Asset tracking*

The EM260 can only be purchased with the EmberZNet stack. This technical datasheet details the EM260 features available to customers using it with the EmberZNet stack.

Contents

1	Pin Assignment	5	5.2.5 Spacing	22	
2	Top-Level Functional Description	7	5.2.6 Waking the EM260 from Sleep	22	
3	Electrical Characteristics	9	5.2.7 Error Conditions	22	
3.1	Absolute Maximum Ratings	9	5.3 SPI Protocol Timing	23	
3.2	Recommended Operating Conditions	9	5.4 Data Format	24	
3.3	Environmental Characteristics	9	5.5 SPI Byte	25	
3.4	DC Electrical Characteristics	10	5.5.1 Primary SPI Bytes	25	
3.5	Digital I/O Specifications	11	5.5.2 Special Response Bytes	26	
3.6	RF Electrical Characteristics	12	5.6 Powering On, Power Cycling, and Rebooting	26	
3.6.1	Receive	12	5.6.1 Unexpected Resets	26	
3.6.2	Transmit	13	5.7 Transaction Examples	27	
3.6.3	Synthesizer	13	5.7.1 SPI Protocol Version	27	
4	Functional Description	14	5.7.2 EmberZNet Serial Protocol Frame—NOP Command	28	
4.1	Receive (RX) Path	14	5.7.3 EM260 Reset	29	
4.1.1	RX Baseband	14	5.7.4 Three-Part Transaction: Wake, Get Version, Stack Status Callback	30	
4.1.2	RSSI and CCA	14	6	EmberZNet Serial Protocol	32
4.2	Transmit (TX) Path	14	6.1	Byte Order	32
4.2.1	TX Baseband	15	6.2	Conceptual Overview	32
4.2.2	TX_ACTIVE Signal	15	6.2.1	Stack Configuration	32
4.3	Integrated MAC Module	15	6.2.2	Policy Settings	34
4.4	Packet Trace Interface (PTI)	15	6.2.3	Datagram Replies	35
4.5	XAP2b Microprocessor	16	6.2.4	Callbacks	35
4.6	Embedded Memory	16	6.2.5	Power Management	35
4.6.1	Simulated EEPROM	16	6.2.6	Tokens	35
4.6.2	Flash Information Area (FIA)	16	6.2.7	RAM	36
4.7	Encryption Accelerator	17	6.2.8	EM260 Status	36
4.8	Reset Detection	17	6.2.9	Random Number Generator	36
4.9	Power-on-Reset (POR)	17	6.3	Protocol Format	36
4.10	Clock Sources	17	6.3.1	Type Definitions	38
4.10.1	High-Frequency Crystal Oscillator	18	6.3.2	Structure Definitions	39
4.10.2	Internal RC Oscillator	18	6.3.3	Named Values	39
4.11	Random Number Generator	19	6.3.4	Configuration Frames	49
4.12	Watchdog Timer	19	6.3.5	Utilities Frames	51
4.13	Sleep Timer	19	6.3.6	Networking Frames	55
4.14	Power Management	19	6.3.7	Binding Frames	63
5	SPI Protocol	20	6.3.8	Messaging Frames	65
5.1	Physical Interface Configuration	20	6.3.9	Alphabetical List of Frames	75
5.2	SPI Transaction	20	6.4	Sample Transactions	77
5.2.1	Command Section	21	6.4.1	Joining	77
5.2.2	Wait Section	21	6.4.2	Binding	78
5.2.3	Response Section	21	6.4.3	Sending	78
5.2.4	Asynchronous Signaling	21	6.4.4	Receiving	79

7	SIF Module Programming and Debug Interface	80	10	Ordering Information	84
8	Typical Application	81	11	Abbreviations and Acronyms	85
9	Mechanical Details	83	12	References	87

1 Pin Assignment

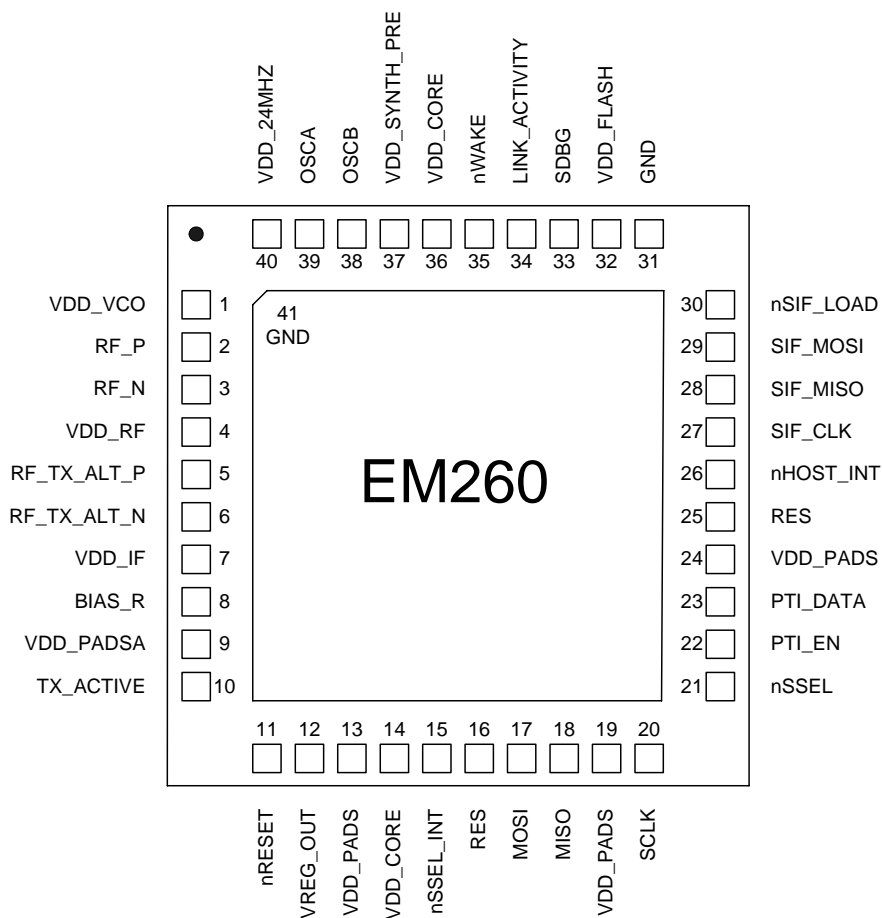

Figure 1. EM260 Pin Assignment

Table 1. Pin Descriptions

Pin #	Signal	Direction	Description
1	VDD_VCO	Power	1.8V VCO supply
2	RF_P	I/O	Differential (with RF_N) receiver input/transmitter output
3	RF_N	I/O	Differential (with RF_P) receiver input/transmitter output
4	VDD_RF	Power	1.8V RF supply (LNA and PA)
5	RF_TX_ALT_P	O	Differential (with RF_TX_ALT_N) transmitter output (optional)
6	RF_TX_ALT_N	O	Differential (with RF_TX_ALT_P) transmitter output (optional)
7	VDD_IF	Power	1.8V IF supply (mixers and filters)
8	BIAS_R	I	Bias setting resistor
9	VDD_PADSA	Power	Analog pad supply (1.8V)
10	TX_ACTIVE	O	Logic-level control for external RX/TX switch The EM260 baseband controls TX_ACTIVE and drives it high (1.8V) when in TX mode. (Refer to Table 6 and section 4.2.2.)

Pin #	Signal	Direction	Description
11	nRESET	I	Active low chip reset (internal pull-up)
12	VREG_OUT	Power	Regulator output (1.8V)
13	VDD_PADS	Power	Pads supply (2.1 - 3.6V)
14	VDD_CORE	Power	1.8V digital core supply
15	nSSEL_INT	I	SPI Slave Select Interrupt (from Host to EM260) This signal must be connected to nSSEL (Pin 21)
16	RES		Reserved for future use, do not connect to any signal.
17	MOSI	I	SPI Data, Master Out / Slave In (from Host to EM260)
18	MISO	O	SPI Data, Master In / Slave Out (from EM260 to Host)
19	VDD_PADS	Power	Pads supply (2.1 - 3.6V)
20	SCLK	I	SPI Clock (from Host to EM260)
21	nSSEL	I	SPI Slave Select (from Host to EM260)
22	PTI_EN	O	Frame signal of Packet Trace Interface (PTI)
23	PTI_DATA	O	Data signal of Packet Trace Interface (PTI)
24	VDD_PADS	Power	Pads supply (2.1 - 3.6V)
25	RES		Reserved for future use, do not connect to any signal.
26	nHOST_INT	O	Host Interrupt signal (from EM260 to Host)
27	SIF_CLK	I	Serial Interface, Clock (internal pull down)
28	SIF_MISO	O	Serial Interface, Master In / Slave Out
29	SIF_MOSI	I	Serial Interface, Master Out / Slave In
30	nSIF_LOAD	I/O	Serial Interface, load strobe (open collector with internal pull up)
31	GND	Power	Ground Supply
32	VDD_FLASH	Power	1.8V Flash memory supply
33	SDBG	O	Spare Debug signal
34	LINK_ACTIVITY	O	Link and Activity signal
35	nWAKE	I	Wake Interrupt signal (from Host to EM260)
36	VDD_CORE	Power	1.8V digital core supply
37	VDD_SYNTH_PRE	Power	1.8V synthesizer and prescaler supply
38	OSCB	I/O	24MHz crystal oscillator or left open for when using an external clock input on OSCA
39	OSCA	I/O	24MHz crystal oscillator or external clock input
40	VDD_24MHZ	Power	1.8V high-frequency oscillator supply
41	GND	Ground	Ground supply pad in the bottom center of the package forms Pin 41 (see the <i>EM260 Reference Design</i> for PCB considerations)

2 Top-Level Functional Description

Figure 2 shows a detailed block diagram of the EM260.

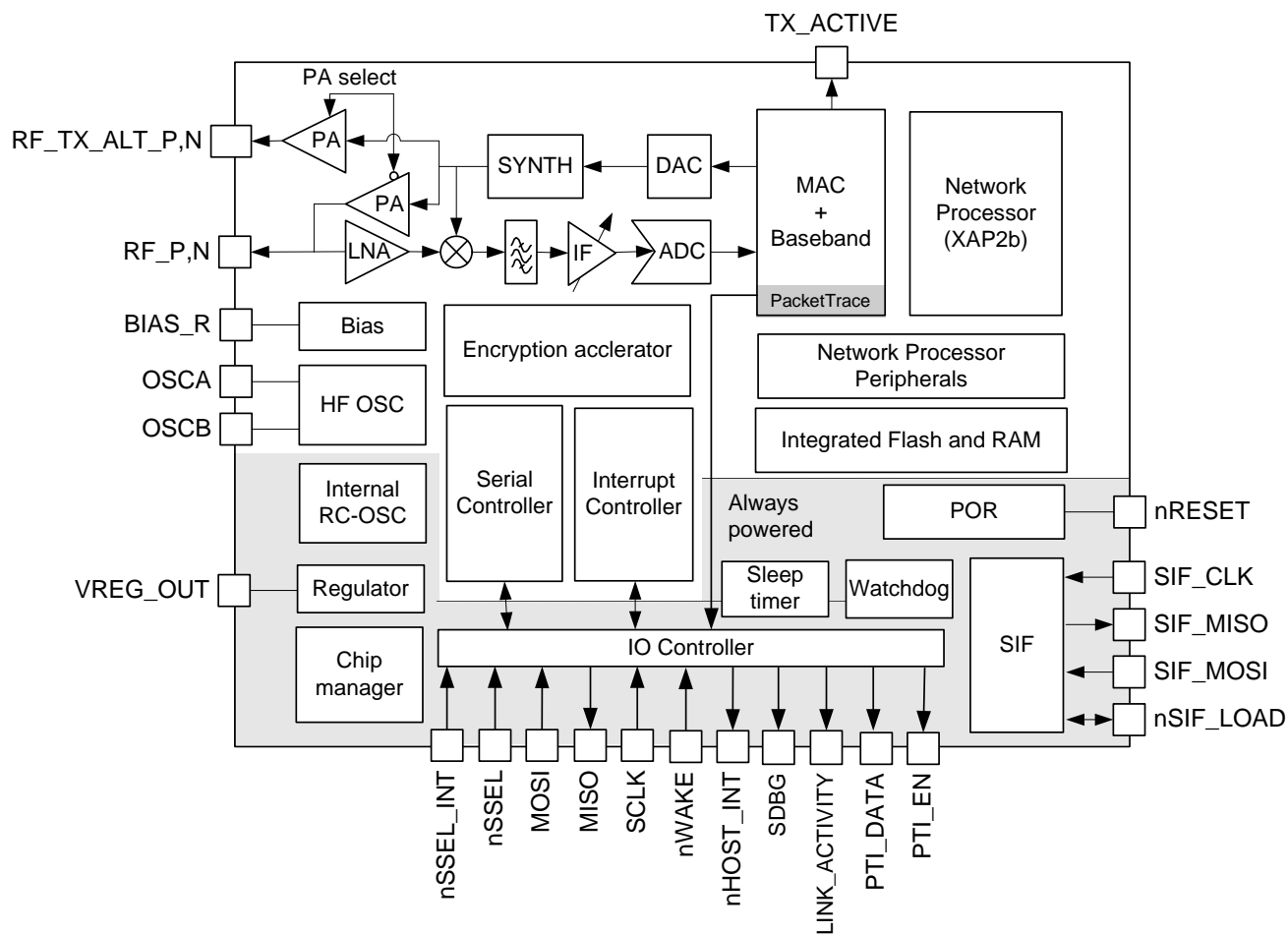

Figure 2. EM260 Block Diagram

The radio receiver is a low-IF, super-heterodyne receiver. It utilizes differential signal paths to minimize noise interference, and its architecture has been chosen to optimize co-existence with other devices within the 2.4GHz band (namely, IEEE 802.11g and Bluetooth). After amplification and mixing, the signal is filtered and combined prior to being sampled by an ADC.

The digital receiver implements a coherent demodulator to generate a chip stream for the hardware-based MAC. In addition, the digital receiver contains the analog radio calibration routines and control of the gain within the receiver path.

The radio transmitter utilizes an efficient architecture in which the data stream directly modulates the VCO. An integrated PA boosts the output power. The calibration of the TX path as well as the output power is controlled by digital logic. If the EM260 is to be used with an external PA, the TX_ACTIVE signal should be used to control the timing of the external switching logic.

The integrated 4.8 GHz VCO and loop filter minimize off-chip circuitry. Only a 24MHz crystal with its loading capacitors is required to properly establish the PLL reference signal.

The MAC interfaces the data memory to the RX and TX baseband modules. The MAC provides hardware-based IEEE 802.15.4 packet-level filtering. It supplies an accurate symbol time base that minimizes the synchroniza-

tion effort of the software stack and meets the protocol timing requirements. In addition, it provides timer and synchronization assistance for the IEEE 802.15.4 CSMA-CA algorithm.

The EM260 integrates hardware support for a Packet Trace module, which allows robust packet-based debug. This element is a critical component of InSight Desktop, the Ember software IDE, providing advanced network debug capability when coupled with the InSight Adapter.

The EM260 integrates a 16-bit XAP2b microprocessor developed by Cambridge Consultants Ltd. This power-efficient, industry-proven core provides the appropriate level of processing power to meet the needs of the Ember ZigBee-compliant stack, EmberZNet. In addition, the SIF module provides a non-intrusive programming and debug interface allowing for real-time application debugging.

The EM260 exposes the Ember Serial API over the SPI, which allows application development to occur on a Host microcontroller of choice. In addition to the four SPI signals, two additional signals, nHOST_INT and nWAKE, provide an easy-to-use handshake mechanism between the Host and the EM260.

The integrated voltage regulator generates a regulated 1.8V reference voltage from an unregulated supply voltage. This voltage is decoupled and routed externally to supply the 1.8V to the core logic. In addition, an integrated POR module allows for the proper cold start of the EM260.

The EM260 contains one high-frequency (24MHz) crystal oscillator and, for low-power operation, a second low-frequency internal 10 kHz oscillator.

The EM260 contains two power domains. The always-powered High Voltage Supply is used for powering the GPIO pads and critical chip functions. The rest of the chip is powered by a regulated Low Voltage Supply which can be disabled during deep sleep to reduce the power consumption.

3 Electrical Characteristics

3.1 Absolute Maximum Ratings

Table 2 lists the absolute maximum ratings for the EM260.

Table 2. Absolute Maximum Ratings

Parameter	Test Conditions	Min.	Max.	Unit
Regulator voltage (VDD_PADS)		- 0.3	3.6	V
Core voltage (VDD_24MHZ, VDD_VCO, VDD_RF, VDD_IF, VDD_PADSA, VDD_FLASH, VDD_SYNTH_PRE, VDD_CORE)		- 0.3	2.0	V
Voltage on RF_P,N; RF_TX_ALT_P,N		- 0.3	3.6	V
Voltage on nSSEL_INT, MOSI, MISO, SCLK, nSSEL, PTI_EN, PTI_DATA, nHOST_INT, SIF_CLK, SIF_MISO, SIF_MOSI, nSIF_LOAD, SDBG, LINK_ACTIVITY, nWAKE, nRESET, VREG_OUT		- 0.3	VDD_PADS+0.3	V
Voltage on TX_ACTIVE, BIAS_R, OSCA, OSCB		- 0.3	VDD_CORE+0.3	V
Storage temperature		- 40	+ 140	°C

3.2 Recommended Operating Conditions

Table 3 lists the rated operating conditions of the EM260.

Table 3. Operating Conditions

Parameter	Test Conditions	Min.	Typ.	Max.	Unit
Regulator input voltage (VDD_PADS)		2.1		3.6	V
Core input voltage (VDD_24MHZ, VDD_VCO, VDD_RF, VDD_IF, VDD_PADSA, VDD_FLASH, VDD_SYNTH_PRE, VDD_CORE)		1.7	1.8	1.9	V
Temperature range		- 40		+ 85	°C

3.3 Environmental Characteristics

Table 4 lists the environmental characteristics of the EM260.

Table 4. Environmental Characteristics

Parameter	Test Conditions	Min.	Typ.	Max.	Unit
ESD (human body model)	On any Pin	- 2		+ 2	kV
ESD (charged device model)	Non-RF Pins	- 400		+ 400	V
ESD (charged device model)	RF Pins	- 225		+ 225	V
Moisture Sensitivity Level (MSL)			TBD		

3.4 DC Electrical Characteristics

Table 5 lists the DC electrical characteristics of the EM260.

Table 5. DC Characteristics

Parameter	Test Conditions	Min.	Typ.	Max.	Unit
Regulator input voltage (VDD_PADS)		2.1		3.6	V
Power supply range (VDD_CORE)	Regulator output or external input	1.7	1.8	1.9	V
Deep Sleep Current					
Quiescent current, including internal RC oscillator	At 25° C			1.0	μA
RX Current					
Radio receiver, MAC, and baseband (boost mode)			29.0		mA
Radio receiver, MAC, and baseband			27.0		mA
CPU, RAM, and Flash memory	At 25° C and 1.8V core		8.5		mA
Total RX current (= $I_{\text{Radio receiver, MAC and baseband, CPU + } I_{\text{RAM, and Flash memory}}$)	At 25° C, VDD_PADS = 3.0V		35.5		mA
TX Current					
Radio transmitter, MAC, and baseband (boost mode)	At max. TX power (+ 5dBm typical)		33.0		mA
Radio transmitter, MAC, and baseband	At max. TX power (+ 3dBm typical)		27.0		mA
	At 0 dBm typical		24.3		mA
	At min. TX power (- 32dBm typical)		19.5		mA
CPU, RAM, and Flash memory	At 25° C, VDD_PADS = 3.0V		8.5		mA
Total TX current (= $I_{\text{Radio transmitter, MAC and baseband, CPU + } I_{\text{RAM, and Flash memory}}$)	At 25° C and 1.8V core; max. power out		35.5		mA

3.5 Digital I/O Specifications

Table 6 contains the digital I/O specifications for the EM260. The digital I/O power (named VDD_PADS) comes from three dedicated pins (pins 13, 19, and 24). The voltage applied to these pins sets the I/O voltage.

Table 6. Digital I/O Specifications

Parameter	Name	Min.	Typ.	Max.	Unit
Voltage supply	VDD_PADS	2.1		3.6	V
Input voltage for logic 0	V_{IL}	0		$0.2 \times VDD_PADS$	V
Input voltage for logic 1	V_{IH}	$0.8 \times VDD_PADS$		VDD_PADS	V
Input current for logic 0	I_{IL}			-0.5	μA
Input current for logic 1	I_{IH}			0.5	μA
Input pull-up resistor value	R_{IPU}		30		$k\Omega$
Input pull-down resistor value	R_{IPD}		30		$k\Omega$
Output voltage for logic 0	V_{OL}	0		$0.18 \times VDD_PADS$	V
Output voltage for logic 1	V_{OH}	$0.82 \times VDD_PADS$		VDD_PADS	V
Output source current (standard current pad)	I_{OHS}			4	mA
Output sink current (standard current pad)	I_{OLS}			4	mA
Output source current (high current pad: pins 33, 34, and 35)	I_{OHH}			8	mA
Output sink current (high current pad: pins 33, 34, and 35)	I_{OLH}			8	mA
Total output current (for I/O pads)	$I_{OH} + I_{OL}$			40	mA
Input voltage threshold for OSCA		$0.2 \times VDD_CORE$		$0.8 \times VDD_PADS$	V
Output voltage level (TX_ACTIVE)		$0.18 \times VDD_CORE$		$0.82 \times VDD_CORE$	V
Output source current (TX_ACTIVE)				1	mA

3.6 RF Electrical Characteristics

3.6.1 Receive

Table 7 lists the key parameters of the integrated IEEE 802.15.4 receiver on the EM260.

Note: Receive Measurements were collected with Ember's EM260 Reference Design at 2440MHz. The Typical number indicates one standard deviation above the mean.

Table 7. Receive Characteristics

Parameter	Test Conditions	Min.	Typ.	Max.	Unit
Frequency range		2400		2500	MHz
Sensitivity (boost mode)	1% PER, 20byte packet defined by IEEE 802.15.4	- 93	- 98.5		dBm
Sensitivity	1% PER, 20byte packet defined by IEEE 802.15.4	- 92	- 97.5		dBm
High-side adjacent channel rejection	IEEE 802.15.4 signal at -82dBm		35		dB
Low-side adjacent channel rejection	IEEE 802.15.4 signal at - 82dBm		35		dB
2 nd high-side adjacent channel rejection	IEEE 802.15.4 signal at - 82dBm		40		dB
2 nd low-side adjacent channel rejection	IEEE 802.15.4 signal at - 82dBm		40		dB
Channel rejection for all other channels	IEEE 802.15.4 signal at - 82dBm		40		dB
802.11g rejection centered at + 12MHz or - 13MHz	IEEE 802.15.4 signal at - 82dBm		40		dB
Maximum input signal level for correct operation (low gain)		0			dBm
Image suppression			30		dB
Co-channel rejection	IEEE 802.15.4 signal at - 82dBm		- 6		dBc
Relative frequency error (2 x 40 ppm required by IEEE 802.15.4)		- 120		+ 120	ppm
Relative timing error (2 x 40 ppm required by IEEE 802.15.4)		- 120		+ 120	ppm
Linear RSSI range			40		dB

3.6.2 Transmit

Table 8 lists the key parameters of the integrated IEEE 802.15.4 transmitter on the EM260.

Note: Transmit Measurements were collected with Ember's EM260 Reference Design at 2440MHz. The Typical number indicates one standard deviation below the mean.

Table 8. Transmit Characteristics

Parameter	Test Conditions	Min.	Typ.	Max.	Unit
Maximum output power (boost mode)	At highest power setting		5		dBm
Maximum output power	At highest power setting	0	3		dBm
Minimum output power	At lowest power setting		- 32		dBm
Error vector magnitude	As defined by IEEE 802.15.4, which sets a 35% maximum		15	25	%
Carrier frequency error		- 40		+ 40	ppm
Load impedance			200		Ω
PSD mask relative	3.5MHz away	- 20			dB
PSD mask absolute	3.5MHz away	- 30			dBm

3.6.3 Synthesizer

Table 9 lists the key parameters of the integrated synthesizer on the EM260.

Table 9. Synthesizer Characteristics

Parameter	Test Conditions	Min.	Typ.	Max.	Unit
Frequency range		2400		2500	MHz
Frequency resolution			11.7		kHz
Lock time	From off, with correct VCO DAC setting			100	μ s
Relock time	Channel change or RX/TX turnaround (IEEE 802.15.4 defines 192 μ s turnaround time)			100	μ s
Phase noise at 100kHz			- 71		dBc/Hz
Phase noise at 1MHz			- 91		dBc/Hz
Phase noise at 4MHz			- 103		dBc/Hz
Phase noise at 10MHz			- 111		dBc/Hz

4 Functional Description

The EM260 connects to the Host microcontroller through a standard SPI interface. The EmberZNet Serial Protocol (EZSP) has been defined to allow an application to be written on a host microcontroller of choice. Therefore, the EM260 comes with a license to EmberZNet, the Ember ZigBee-compliant software stack. The following brief description of the hardware modules provides the necessary background on the operation of the EM260. For more information, contact www.ember.com/support.

4.1 Receive (RX) Path

The EM260 RX path spans the analog and digital domains. The RX architecture is based on a low-IF, super-heterodyne receiver. It utilizes differential signal paths to minimize noise interference. The input RF signal is mixed down to the IF frequency of 4MHz by I and Q mixers. The output of the mixers is filtered and combined prior to being sampled by a 12MSPS ADC. The RX filtering within the RX path has been designed to optimize the co-existence of the EM260 with other 2.4GHz transceivers, such as the IEEE 802.11g and Bluetooth.

4.1.1 RX Baseband

The EM260 RX baseband (within the digital domain) implements a coherent demodulator for optimal performance. The baseband demodulates the O-QPSK signal at the chip level and synchronizes with the IEEE 802.15.4-2003 preamble. Once a packet preamble is detected, it de-spreads the demodulated data into 4-bit symbols. These symbols are buffered and passed to the hardware-based MAC module for filtering.

In addition, the RX baseband provides the calibration and control interface to the analog RX modules, including the LNA, RX Baseband Filter, and modulation modules. The EmberZNet software includes calibration algorithms which use this interface to reduce the effects of process and temperature variation.

4.1.2 RSSI and CCA

The EM260 calculates the RSSI over an 8-symbol period as well as at the end of a received packet. It utilizes the RX gain settings and the output level of the ADC within its algorithm.

The EM260 RX baseband provides support for the IEEE 802.15.4-2003 required CCA methods summarized in Table 10. Modes 1, 2, and 3 are defined by the 802.15.4-2003 standard; Mode 0 is a proprietary mode.

Table 10. CCA Mode Behavior

CCA Mode	Mode Behavior
0	Clear channel reports busy medium if either carrier sense OR RSSI exceeds their thresholds.
1	Clear channel reports busy medium if RSSI exceeds its threshold.
2	Clear channel reports busy medium if carrier sense exceeds its threshold.
3	Clear channel reports busy medium if both RSSI and carrier sense exceed their thresholds.

4.2 Transmit (TX) Path

The EM260 transmitter utilizes both analog circuitry and digital logic to produce the O-QPSK modulated signal. The area-efficient TX architecture directly modulates the spread symbols prior to transmission. The differential signal paths increase noise immunity and provide a common interface for the external balun.

4.2.1 TX Baseband

The EM260 TX baseband (within the digital domain) performs the spreading of the 4-bit symbol into its IEEE 802.15.4-2003-defined 32-chip I and Q sequence. In addition, it provides the interface for software to perform the calibration of the TX module in order to reduce process, temperature, and voltage variations.

4.2.2 TX_ACTIVE Signal

Even though the EM260 provides an output power suitable for most ZigBee applications, some applications will require an external power amplifier (PA). Due to the timing requirements of IEEE 802.15.4-2003, the EM260 provides a signal, TX_ACTIVE, to be used for external PA power management and RF Switching logic. When in TX, the TX Baseband drives TX_ACTIVE high (as described in Table 6). When in RX, the TX_ACTIVE signal is low. If an external PA is not required, then the TX_ACTIVE signal should be connected to GND through a 100k Ohm resistor, as shown in the application circuit in Figure 12.

4.3 Integrated MAC Module

The EM260 integrates critical portions of the IEEE 802.15.4-2003 MAC requirements in hardware. This allows the EM260 to provide greater bandwidth to application and network operations. In addition, the hardware acts as a first-line filter for non-intended packets. The EM260 MAC utilizes a DMA interface to RAM memory to further reduce the overall microcontroller interaction when transmitting or receiving packets.

When a packet is ready for transmission, the software configures the TX MAC DMA by indicating the packet buffer RAM location. The MAC waits for the backoff period, then transitions the baseband to TX mode and performs channel assessment. When the channel is clear, the MAC reads data from the RAM buffer, calculates the CRC, and provides 4-bit symbols to the baseband. When the final byte has been read and sent to the baseband, the CRC remainder is read and transmitted.

The MAC resides in RX mode most of the time, and different format and address filters keep non-intended packets from using excessive RAM buffers, as well as preventing the EM260 CPU from being interrupted. When the reception of a packet begins, the MAC reads 4-bit symbols from the baseband and calculates the CRC. It assembles the received data for storage in a RAM buffer. A RX MAC DMA provides direct access to the RAM memory. Once the packet has been received, additional data is appended to the end of the packet in the RAM buffer space. The appended data provides statistical information on the packet for the software stack.

The primary features of the MAC are:

- CRC generation, appending, and checking
- Hardware timers and interrupts to achieve the MAC symbol timing
- Automatic preamble, and SFD pre-pended to a TX packet
- Address recognition and packet filtering on received packets
- Automatic acknowledgement transmission
- Automatic transmission of packets from memory
- Automatic transmission after backoff time if channel is clear (CCA)
- Automatic acknowledgement checking
- Time stamping of received and transmitted messages
- Attaching packet information to received packets (LQI, RSSI, gain, time stamp, and packet status)
- IEEE 802.15.4-2003 timing and slotted/unslotted timing

4.4 Packet Trace Interface (PTI)

The EM260 integrates a true PHY-level PTI for effective network-level debugging. This two-signal interface monitors all the PHY TX and RX packets (in a non-intrusive manner) between the MAC and baseband modules. It is an asynchronous 500kbps interface and cannot be used to inject packets into the PHY/MAC interface. The

two signals from the EM260 are the frame signal (PTI_EN) and the data signal (PTI_DATA). The PTI is supported by InSight Desktop.

4.5 XAP2b Microprocessor

The EM260 integrates the XAP2b microprocessor developed by Cambridge Consultants Ltd., making it a true network processor solution. The XAP2b is a 16-bit Harvard architecture processor with separate program and data address spaces. The word width is 16 bits for both the program and data sides.

The standard XAP2 microprocessor and accompanying software tools have been enhanced to create the XAP2b microprocessor used in the EM260. The XAP2b adds data-side byte addressing support to the XAP2 allowing for more productive usage of RAM and optimized code.

The XAP2b clock speed is 12MHz. When used with the EmberZNet stack, firmware is loaded into Flash memory over the air or by a serial link using a built-in bootloader in a reserved area of the Flash. Alternatively, firmware may be loaded via the SIF interface with the assistance of RAM-based utility routines also loaded via SIF.

4.6 Embedded Memory

The EM260 contains embedded Flash and RAM memory for firmware storage and execution. In addition it partitions a portion of the Flash for Simulated EEPROM and token storage.

4.6.1 Simulated EEPROM

The Ember stack reserves a section of Flash memory to provide Simulated EEPROM storage area for stack and customer tokens. The Flash cell has been qualified for a data retention time of >100 years at room temperature and is rated to have a guaranteed 1,000 write/erase cycles. Because the Flash cells are qualified for up to 1,000 write cycles, the Simulated EEPROM implements an effective wear-leveling algorithm which effectively extends the number of write cycles for individual tokens.

The number of set-token operations is finite due to the write cycle limitation of the Flash. It is not possible to guarantee an exact number of set-token operations because the life of the Simulated EEPROM depends on which tokens are written and how often.

The EM260 stores non-volatile information necessary for network operation as well as 8 tokens available to the Host (see section 6.2.6, Tokens). The majority of internal tokens are only written when the EM260 performs a network join or leave operation. As a simple ballpark estimate of possible set-token operations, consider an EM260 in a stable network (no joins or leaves) not sending any messages and the Host is using only one of the 8-byte tokens available to it. Under this scenario, a very rough estimate results in approximately 330,000 possible set-token operations. The number of possible set-token calls, though, depends on which tokens are being set, so the ratios of set-token calls for each token plays a large factor. A very rough estimate for the total number of times an App token can be set is approximately 320,000.

These estimates would typically increase if the EM260 is kept closer to room temperature, since the 1,000 guaranteed write cycles of the Flash is for across temperature.

4.6.2 Flash Information Area (FIA)

The EM260 also includes a separate 1024-byte FIA that can be used for storage of data during manufacturing, including serial numbers and calibration values. Programming of this special Flash page can only be enabled using the SIF interface to prevent accidental corruption or erasure. The EmberZNet stack reserves a small portion of this space for its own use and in addition makes eight manufacturing tokens available to the application. See section 6.2.6, Tokens, for more information.

4.7 Encryption Accelerator

The EM260 contains a hardware AES encryption engine that is attached to the CPU using a memory-mapped interface. NIST-based CCM, CCM*, CBC-MAC, and CTR modes are implemented in hardware. These modes are described in the IEEE 802.15.4-2003 specification, with the exception of CCM*, which is described in the ZigBee Security Services Specification 1.0. The EmberZNet stack implements a security API for applications that require security at the application level.

4.8 Reset Detection

The EM260 contains multiple reset sources. The reset event is logged into the reset source register, which lets the CPU determine the cause of the last reset. The following reset causes are detected:

- Power-on-Reset
- Watchdog
- PC rollover
- Software reset
- Core Power Dip

4.9 Power-on-Reset (POR)

Each voltage domain (1.8V Digital Core Supply VDD_CORE and Pads Supply VDD_PADS) has a power-on-reset (POR) cell.

The VDD_PADS POR cell holds the always-powered high-voltage domain in reset until the following conditions have been met:

- The high-voltage Pads Supply VDD_PADS voltage rises above a threshold.
- The internal RC clock starts and generates three clock pulses.
- The 1.8V POR cell holds the main digital core in reset until the regulator output voltage rises above a threshold.

Additionally, the digital domain counts 1,024 clock edges on the 24MHz crystal before releasing the reset to the main digital core.

Table 11 lists the features of the EM260 POR circuitry.

Table 11. POR Specifications

Parameter	Min.	Typ.	Max.	Unit
VDD_PADS POR release	1.0	1.2	1.4	V
VDD_PADS POR assert	0.5	0.6	0.7	V
1.8V POR release	1.35	1.5	1.65	V
1.8V POR hysteresis	0.08	0.1	0.12	V

4.10 Clock Sources

The EM260 integrates two oscillators: a high-frequency 24MHz crystal oscillator and a low-frequency internal 10kHz RC oscillator.

4.10.1 High-Frequency Crystal Oscillator

The integrated high-frequency crystal oscillator requires an external 24MHz crystal with an accuracy of ± 40 ppm. Based upon the application Bill of Materials and current consumption requirements, the external crystal can cover a range of ESR requirements. For a lower ESR, the cost of the crystal increases but the overall current consumption decreases. Likewise, for higher ESR, the cost decreases but the current consumption increases. Therefore, the designer can choose a crystal to fit the needs of the application.

Table 12 lists the specifications for the high-frequency crystal.

Table 12. High-Frequency Crystal Specifications

Parameter	Test Conditions	Min.	Typ.	Max.	Unit
Frequency			24		MHz
Duty cycle		40		60	%
Phase noise from 1kHz to 100kHz				- 120	dBc/Hz
Accuracy	Initial, temperature, and aging	- 40		+ 40	ppm
Crystal ESR	Load capacitance of 10pF			100	Ω
Crystal ESR	Load capacitance of 18pF			60	Ω
Start-up time to stable clock (max. bias)				1	ms
Start-up time to stable clock (optimum bias)				2	ms
Current consumption	Good crystal: 20 Ω ESR, 10pF load		0.2	0.3	mA
Current consumption	Worst-case crystals (60 Ω , 18pF or 100 Ω , 10pF)			0.5	mA
Current consumption	At maximum bias			1	mA

4.10.2 Internal RC Oscillator

The EM260 has a low-power, low-frequency RC oscillator that runs all the time. Its nominal frequency is 10kHz. It is divided down to 1kHz using a variable divider to allow software to accurately calibrate it. This calibrated clock is used by the sleep timer.

Timekeeping accuracy depends on temperature fluctuations the chip is exposed to, power supply impedance, and the calibration interval, but in general it will be better than 150ppm (including crystal error of 40ppm).

Table 13 lists the specifications of the RC oscillator.

Table 13. RC Oscillator Specifications

Parameter	Test Conditions	Min.	Typ.	Max.	Unit
Frequency			10		kHz
Analog trim steps			1		kHz
Frequency variation with supply	For a voltage drop from 3.6V to 3.1V or 2.6V to 2.1V		0.75	1.5	%

4.11 Random Number Generator

The EM260 allows for the generation of random numbers by exposing a randomly generated bit from the RX ADC. Analog noise current is passed through the RX path, sampled by the receive ADC, and stored in a register. The value contained in this register could be used to seed a software-generated random number. The EmberZNet stack utilizes these random numbers to seed the Random MAC Backoff and Encryption Key Generators.

4.12 Watchdog Timer

The EM260 contains an internal watchdog timer clocked from the internal oscillator. If the timer reaches its time-out value of approximately 2 seconds, it will reset the EM260. This reset signal cannot be routed externally to the Host.

The EM260 firmware will periodically restart the watchdog timer while the firmware is running normally. The Host cannot effect or configure the watchdog timer.

4.13 Sleep Timer

The 16-bit sleep timer is contained in the always-powered digital block. The clock source for the sleep timer is a calibrated 1kHz clock. The frequency is slowed down with a 2^N prescaler to generate a final timer resolution of 1ms. With a 1ms tick and a 16-bit timer, the timer wraps about every 65.5 seconds. The EmberZNet stack appropriately handles timer wraps allowing the Host to order a theoretical maximum sleep delay of 4 million seconds.

4.14 Power Management

The EM260 supports four different power modes: active, idle, deep sleep, and power down.

Active mode is the normal, operating state of the EM260.

While in idle mode, code execution halts until any interrupt occurs. All modules of the EM260 including the radio continue to operate normally. The EmberZNet stack automatically invokes idle as appropriate.

Deep sleep mode and power down mode both power off most of the EM260, including the radio, and leave only the critical chip functions powered. The internal regulator is disabled and VREG_OUT is turned off. All output signals are maintained in a frozen state. Upon waking from deep sleep or power down mode, the internal regulator is reenabled. Deep sleep and power down result in the same sleep current consumption. The two sleep modes differ as follows: the EM260 can wake on both an internal timer and an external signal from deep sleep mode; power down mode can only wake on an external signal.

5 SPI Protocol

The EM260 Low Level Protocol centers on the SPI interface for communication with a pair of GPIO for hand-shake signaling.

- The EM260 looks like a hardware peripheral.
- The EM260 is the slave device and all transactions are initiated by the Host (the master).
- The EM260 supports a reasonably high data rate.

5.1 Physical Interface Configuration

The EM260 supports both SPI Slave Mode 0 (clock is idle low, sample on rising edge) and SPI Slave Mode 3 (clock is idle high, sample on rising edge) at a maximum SPI clock rate of 5MHz, as illustrated in Figure 3. The convention for the waveforms in this document is to show Mode 0.

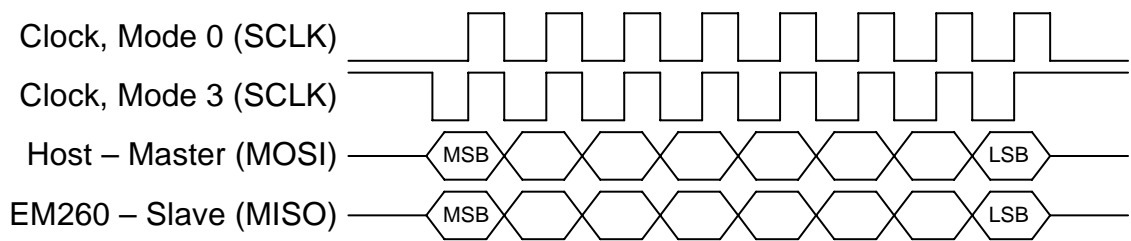

Figure 3. SPI Transfer Format, Mode 0 and Mode 3

The nHOST_INT signal and the nWAKE signal are both active low. The Host must supply a pull-up resistor on the nHOST_INT signal to prevent errant interruptions during undefined events such as the EM260 resetting. The EM260 supplies an internal pull-up on the nWAKE signal to prevent errant interruptions during undefined events such as the Host resetting.

5.2 SPI Transaction

The basic EM260 SPI transaction is half-duplex to ensure proper framing and to give the EM260 adequate response time. The basic transaction, as shown in Figure 4, is composed of three sections: Command, Wait, and Response. The transaction can be considered analogous to a function call. The Command section is the function call, and the Response section is the return value.

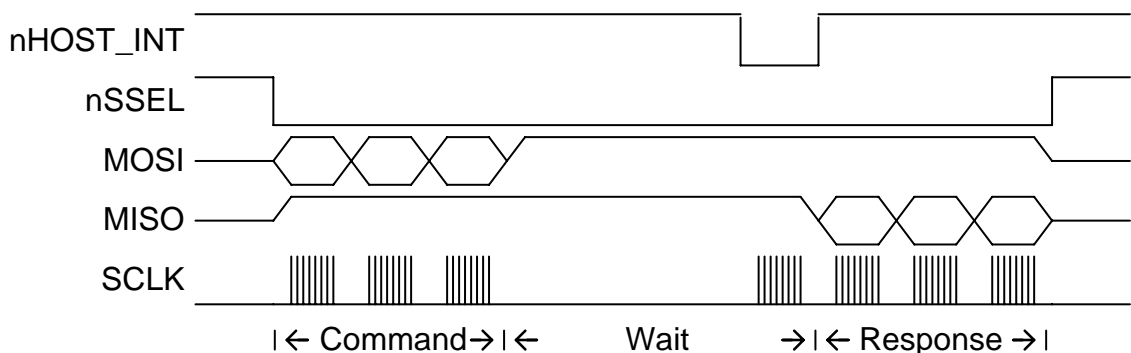

Figure 4. General Timing Diagram for a SPI Transaction

5.2.1 Command Section

The Host begins the transaction by asserting the Slave Select and then sending a command to the EM260. This command can be of any length from 2 to 128 bytes and must not begin with `0xFF`. During the Command section, the EM260 will respond with only `0xFF`. The Host should ignore data on MISO during the Command section. Once the Host has completed transmission of the entire message, the transaction moves to the Wait section.

5.2.2 Wait Section

The Wait section is a period of time during which the EM260 may be processing the command or performing other operations. Note that this section can be any length of time up to 200 milliseconds. Because of the variable size of the Wait section, an interrupt-driven or polling-driven method is suggested for clocking the SPI as opposed to a DMA method. Since the EM260 can require up to 200 milliseconds to respond, as long as the Host keeps Slave Select active, the Host can perform other tasks while waiting for a Response.

To determine when a Response is ready, use one of two methods:

- Clock the SPI until the EM260 transmits a byte other than `0xFF`.
- Interrupt on the falling edge of `nHOST_INT`.

The first method, clocking the SPI, is recommended due to simplicity in implementing. During the Wait section, the EM260 will transmit only `0xFF` and will ignore all incoming data until the Response is ready. When the EM260 transmits a byte other than `0xFF`, the transaction has officially moved into the Response section. Therefore, the Host can poll for a Response by continuing to clock the SPI by transmitting `0xFF` and waiting for the EM260 to transmit a byte other than `0xFF`. The EM260 will also indicate that a Response is ready by asserting the `nHOST_INT` signal. The falling edge of `nHOST_INT` is the indication that a Response is ready. Once the `nHOST_INT` signal asserts, `nHOST_INT` will return to idle after the Host begins to clock data.

5.2.3 Response Section

When the EM260 transmits a byte other than `0xFF`, the transaction has officially moved into the Response section. The data format is the same format used in the Command section. The response can be of any length from 2 to 128 bytes and will not begin with `0xFF`. Depending on the actual response, the length of the response is known from the first or second byte and this length should be used by the Host to clock out exactly the correct number of bytes. Once all bytes have been clocked, it is allowable for the Host to deassert chip select. Since the Host is in control of clocking the SPI, there are no ACKs or similar signals needed back from the Host because the EM260 will assume the Host could accept the bytes being clocked on the SPI. After every transaction, the Host must hold the Slave Select high for a minimum of 1ms. This timing requirement is called the inter-command spacing and is necessary to allow the EM260 to process a command and become ready to accept a new command.

5.2.4 Asynchronous Signaling

When the EM260 has data to send to the Host, it will assert the `nHOST_INT` signal. The `nHOST_INT` signal is designed to be an edge-triggered signal as opposed to a level-triggered signal; therefore, the falling edge of `nHOST_INT` is the true indicator of data availability. The Host then has the responsibility to initiate a transaction to ask the EM260 for its output. The Host should initiate this transaction as soon as possible to prevent possible backup of data in the EM260. The EM260 will deassert the `nHOST_INT` signal after receiving a byte on the SPI. Due to inherent latency in the EM260, the timing of when the `nHOST_INT` signal returns to idle can vary between transactions. `nHOST_INT` will always return to idle for a minimum of 10 μ s before asserting again. If the EM260 has more output available after the transaction has completed, the `nHOST_INT` signal will assert again after Slave Select is deasserted and the Host must make another request.

5.2.5 Spacing

To ensure that the EM260 is always able to deal with incoming commands, a minimum inter-command spacing is defined at 1ms. After every transaction, the Host must hold the Slave Select high for a minimum of 1ms. The Host must respect the inter-command spacing requirement, or the EM260 will not have time to operate on the command; additional commands could result in error conditions or undesired behavior. If the nHOST_INT signal is not already asserted, the Host is allowed to use the Wake handshake instead of the inter-command spacing to determine if the EM260 is ready to accept a command.

5.2.6 Waking the EM260 from Sleep

Waking up the EM260 involves a simple handshaking routine as illustrated in Figure 5. This handshaking insures that the Host will wait until the EM260 is fully awake and ready to accept commands from the Host. If the EM260 is already awake when the handshake is performed (such as when the Host resets and the EM260 is already operating), the handshake will proceed as described below with no ill effects.

Note: A wake handshake cannot be performed if nHOST_INT is already asserted.

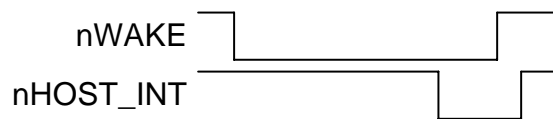

Figure 5. EM260 Wake Sequence

Waking the EM260 involves the following steps:

1. Host asserts nWAKE.
2. EM260 interrupts on nWAKE and exits sleep.
3. EM260 performs all operations it needs to and will not respond until it is ready to accept commands.
4. EM260 asserts nHOST_INT within 10ms of nWAKE asserting. If the EM260 does not assert nHOST_INT within 10ms of nWAKE, it is valid for the Host to consider the EM260 unresponsive and to reset the EM260.
5. Host detects nHOST_INT assertion. Since the assertion of nHOST_INT indicates the EM260 can accept SPI transactions, the Host does not need to hold Slave Select high for the normally required minimum 1ms of inter-command spacing.
6. Host deasserts nWAKE after detecting nHOST_INT assertion.
7. EM260 will deassert nHOST_INT within 25µs of nWAKE deasserting.
8. After 25µs, any change on nHOST_INT will be an indication of a normal asynchronous (callback) event.

5.2.7 Error Conditions

If two or more different error conditions occur back to back, only the first error condition will be reported to the Host (if it is possible to report the error). The following are error conditions that might occur with the EM260.

- **Oversized EZSP Frame:** If the transaction includes an EZSP Frame, the Length Byte cannot be a value greater than 125. If the EM260 detects a length byte greater than 125, it will drop the incoming Command and abort the entire transaction. The EM260 will then assert nHOST_INT after Slave Select returns to Idle to inform the Host through an error code in the Response section what has happened. Not only is the Command in the problematic transaction dropped by the EM260, but the next Command is also dropped, because it is responded to with the Oversized EZSP Frame Error Response.

- Aborted Transaction:** An aborted transaction is any transaction where Slave Select returns to Idle prematurely and the SPI Protocol dropped the transaction. The most common reason for Slave Select returning to Idle prematurely is the Host unexpectedly resetting. If a transaction is aborted, the EM260 will assert nHOST_INT to inform the Host through an error code in the Response section what has happened. When a transaction is aborted, not only does the Command in the problematic transaction get dropped by the EM260, but the next Command also gets dropped since it is responded to with the Aborted Transaction Error Response.
- Missing Frame Terminator:** Every Command and Response must be terminated with the Frame Terminator byte. The EM260 will drop any Command that is missing the Frame Terminator. The EM260 will then immediately provide the Missing Frame Terminator Error Response.
- Long Transaction:** A Long Transaction error occurs when the Host clocks too many bytes. As long as the inter-command spacing requirement is met, this error condition should not cause a problem, since the EM260 will send only 0xFF outside of the Response section as well as ignore incoming bytes outside of the Command section.
- Unresponsive:** Unresponsive can mean the EM260 is not powered, not fully booted yet, incorrectly connected to the Host, or busy performing other tasks. The Host must wait the maximum length of the Wait section before it can consider the EM260 unresponsive to the Command section. This maximum length is 200 milliseconds, measured from the end of the last byte sent in the Command Section. If the EM260 ever fails to respond during the Wait section, it is valid for the Host to consider the EM260 unresponsive and to reset the EM260. Additionally, if nHOST_INT does not assert within 10ms of nWAKE asserting during the wake handshake, the Host can consider the EM260 unresponsive and reset the EM260.

5.3 SPI Protocol Timing

Figure 6 illustrates all critical timing parameters in the SPI Protocol. These timing parameters are a result of the EM260's internal operation and both constrain Host behavior and characterize EM260 operation. The parameters shown are discussed elsewhere in this document. Note that Figure 6 is not drawn to scale, but is instead drawn only to illustrate where the parameters are measured.

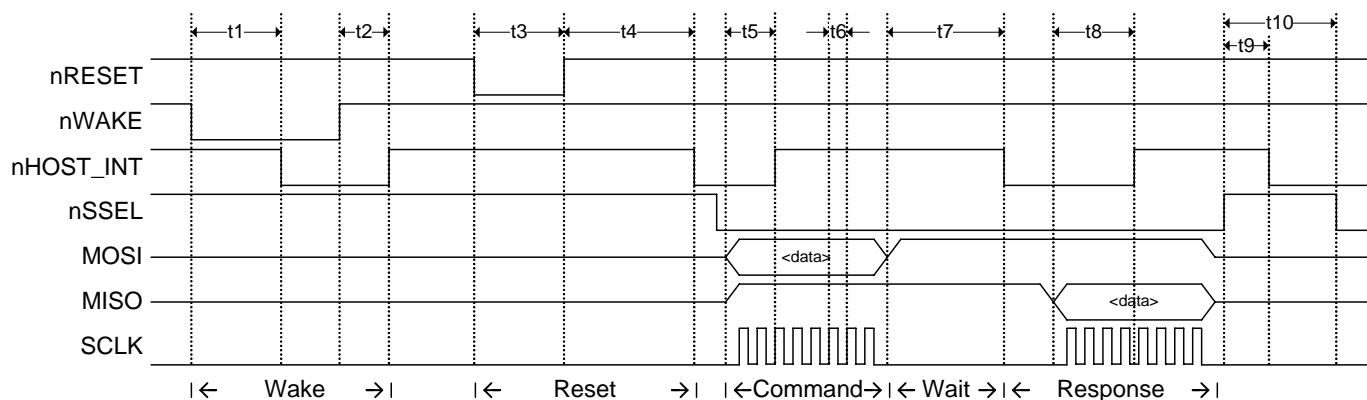

Figure 6. SPI Protocol Timing Waveform

Table 15 lists the timing parameters of the SPI Protocol. These parameters are illustrated in Figure 6.

Table 14. SPI Protocol Timing Parameters

Parameter	Description	Min.	Typ.	Max.	Unit
t1 (a)	Wake handshake, while 260 is awake		133	150	μ s
t1 (b)	Wake handshake, while 260 is asleep		7.3	10	ms

Parameter	Description	Min.	Typ.	Max.	Unit
t2	Wake handshake finish	1.1	1.2	25	μs
t3	Reset pulse width	8			μs
t4	Startup time		250	1500	ms
t5	nHOST_INT deasserting after Command	13	35	75	μs
t6	Clock rate	200			ns
t7	Wait section	25	755	200000	μs
t8	nHOST_INT deasserting after Response	20	130	800	μs
t9	nHOST_INT asserting after transaction	25	70	800	μs
t10	Inter-command spacing	1			ms

5.4 Data Format

The data format, also referred to as a *command*, is the same for both the Command section and the Response section. The data format of the SPI Protocol is straightforward, as illustrated in Figure 7.

SPI Byte	Length or Error	EZSP Frame (Variable Length)	Frame Terminator
----------	-----------------	------------------------------	------------------

Figure 7. SPI Protocol Data Format

The total length of a command must not exceed 128 bytes.

All commands must begin with the *SPI Byte*. Some commands are only two bytes—that is, they contain the SPI Byte and Frame Terminator only.

The *Length Byte* is only included if there is information in the EZSP Frame (EmberZNet Serial Protocol Frame) and the Length Byte defines the length of just the EZSP Frame. Therefore, if a command includes an EZSP Frame, the Length Byte can have a value from 2 through 125 and the overall command size will be 5 through 128 bytes. The SPI Byte can be a specific value indicating if there is an EZSP Frame or not, and if there is an EZSP Frame, then the Length Byte can be expected.

The *Error Byte* is used by the error responses to provide additional information about the error and appears in place of the length byte. This additional information is described in the following sections.

The *EZSP Frame* contains the data needed for operating EmberZNet. The EZSP Frame and its format are explained in Chapter 6, EmberZNet Serial Protocol.

The *Frame Terminator* is a special control byte used to mark the end of a command. The Frame Terminator byte is defined as `0xA7` and is appended to all Commands and Responses immediately after the final data byte. The purpose of the Frame Terminator is to provide a known byte the SPI Protocol can use to detect a corrupt command. For example, if the EM260 resets during the Response Section, the Host will still clock out the correct number of bytes. But when the host attempts to verify the value `0xA7` at the end of the Response, it will see either the value `0x00` or `0xFF` and know that the EM260 just reset and the corrupt Response should be discarded.

Note: The Length Byte only specifies the length of the EZSP Frame. It does not include the Frame Terminator.

5.5 SPI Byte

Table 15 lists the possible commands and their responses in the SPI Byte.

Table 15. SPI Commands & Responses

Command Value	Command	Response Value	Response
Any	Any	0x00	EM260 reset occurred—This is never used in another Response; it always indicates an EM260 Reset.
Any	Any	0x01	Oversized EZSP Frame received—This is never used in another Response; it always indicates an overflow occurred.
Any	Any	0x02	Aborted Transaction occurred—This is never used in another Response; it always indicates an aborted transaction occurred.
Any	Any	0x03	Missing Frame Terminator—This is never used in another Response; it always indicates a Missing Frame Terminator in the Command.
Any	Any	0x04	Reserved
0x00 - 0x0F	Reserved	[none]	[none]
0x0A	SPI Protocol Version	0x81 - 0xBF	bit[7] is always set. bit[6] is always cleared. bit[5:0] is a number from 1-63.
0x0B	SPI Status	0xC0 - 0xC1	bit[7] is always set. bit[6] is always set. bit[0]—Set if Alive.
0xF0 - 0xFD	Reserved	[none]	[none]
0xFE	EZSP Frame	0xFE	EZSP Frame
0xFF	Invalid	0xFF	Invalid

5.5.1 Primary SPI Bytes

There are three primary SPI Bytes: SPI Protocol Version, SPI Status, and EZSP Frame.

- SPI Protocol Version [0x0A]:** Sending this command requests the SPI Protocol Version number from the SPI Interface. The response will always have bit 7 set and bit 6 cleared. In this current version, the response will be 0x81, since the version number corresponding to this set of Command-Response values is version number 1. The version number can be a value from 1 to 63 (0x81-0xBF).
- SPI Status [0x0B]:** Sending this command asks for the EM260 status. The response status byte will always have the upper 2 bits set. In this current version, the status byte only has one status bit [0], which is set if the EM260 is alive and ready for commands.
- EZSP Frame [0xFE]:** This byte indicates that the current transaction is an EZSP transaction and there is more data to follow. This SPI Byte, and only this SPI Byte, will cause the transaction to look like the full data format illustrated in Figure 7. The byte immediately after this SPI Byte will be a Length Byte, and it is used to identify the length of the EZSP Frame. The EZSP Frame is defined in section 6, EmberZNet Serial Protocol. If the SPI Byte is 0xFE, it means the minimum transaction size is five bytes. All other SPI Bytes mean the transaction size is two or three bytes.

5.5.2 Special Response Bytes

There are only five SPI Byte values, 0x00–0x04, ever used as error codes (see Table 16). When the error condition occurs, any command sent to the EM260 will be ignored and responded to with one of these codes. These special SPI Bytes must be trapped and dealt with. In addition, for each error condition the Error Byte (instead of the Length Byte) is also sent with the SPI Byte.

Table 16. Byte Values Used as Error Codes

SPI Byte Value	Error Message	Error Description	Error Byte Description
0x00	EM260 Reset	See section 5.6, Powering On, Power Cycling, and Rebooting.	The reset type. Refer to Ember’s API documentation discussing EmberResetType.
0x01	Oversized EZSP Frame	The command contained an EZSP frame with a Length Byte greater than 125. The EM260 was forced to drop the entire command.	Reserved
0x02	Aborted Transaction	The transaction was not completed properly and the EM260 was forced to abort the transaction.	Reserved
0x03	Missing Frame Terminator	The command was missing the Frame Terminator. The EM260 was forced to drop the entire command.	Reserved
0x04	Reserved	[none]	[none]

5.6 Powering On, Power Cycling, and Rebooting

When the Host powers on (or reboots), it cannot guarantee that the EM260 is awake and ready to receive commands. Therefore, the Host should always perform the Wake EM260 handshake to guarantee that the EM260 is awake. If the EM260 resets, it needs to inform the Host so that the Host can reconfigure the stack if needed.

When the EM260 resets, it will assert the nHOST_INT signal, telling the Host that it has data. The Host should request data from the EM260 as usual. The EM260 will ignore whatever command is sent to it and respond only with two bytes. The first byte will always be 0x00 and the second byte will be the reset type as defined by EmberResetType. This specialty SPI Byte is never used in another Response SPI Byte. If the Host sees 0x00 from the EM260, it knows that the EM260 has been reset. The EM260 will deassert the nHOST_INT signal shortly after receiving a byte on the SPI and process all further commands in the usual manner. In addition to the Host having control of the reset line of the EM260, the EmberZNet Serial Protocol also provides a mechanism for a software reboot.

5.6.1 Unexpected Resets

The EM260 is designed to protect itself against undefined behavior due to unexpected resets. The protection is based on the state of Slave Select since the inter-command spacing mandates that Slave Select must return to idle. The EM260’s internal SPI Protocol uses Slave Select returning to idle as a trigger to reinitialize its SPI Protocol. By always reinitializing, the EM260 is protected against the Host unexpectedly resetting or terminating a transaction. Additionally, if Slave Select is active when the EM260 powers on, the EM260 will ignore SPI data until Slave Select returns to idle. By ignoring SPI traffic until idle, the EM260 will not begin receiving in the middle of a transaction.

If the Host resets, in most cases it should reset the EM260 as well so that both devices are once again in the same state: freshly booted. Alternately, the Host can attempt to recover from the reset by recovering its previous state and resynchronizing with the state of the EM260.

If the EM260 resets during a transaction, the Host can expect either a Wait Section timeout or a missing Frame Terminator indicating an invalid Response.

If the EM260 resets outside of a transaction, the Host should proceed normally.

5.7 Transaction Examples

This section contains the following transaction examples:

- SPI Protocol Version
- EmberZNet Serial Protocol Frame—NOP Command
- EM260 Reset
- Three-Part Transaction: Wake, Get Version, Stack Status Callback

5.7.1 SPI Protocol Version

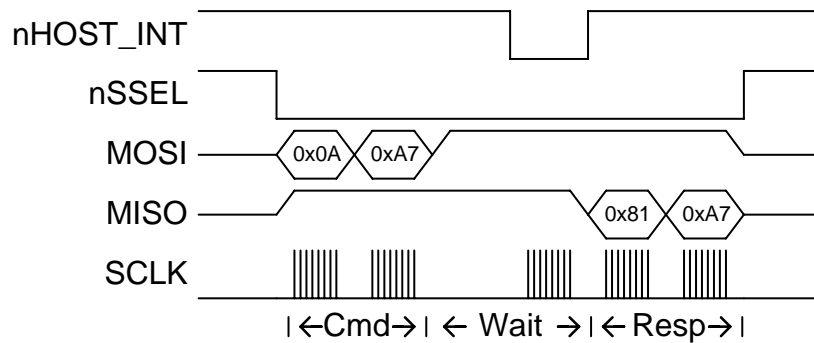

Figure 8. SPI Protocol Version Example

1. Activate Slave Select (nSSEL).
2. Transmit the command 0x0A - SPI Protocol Version Request.
3. Transmit the Frame Terminator, 0xA7.
4. Wait for nHOST_INT to assert.
5. Transmit and receive 0xFF until a byte other than 0xFF is received.
6. Receive response 0x81 (a byte other than 0xFF), then receive the Frame Terminator, 0xA7.
7. Bit 7 is always set and bit 6 is always cleared in the Version Response, so this is Version 1.
8. Deactivate Slave Select.

5.7.2 EmberZNet Serial Protocol Frame—NOP Command

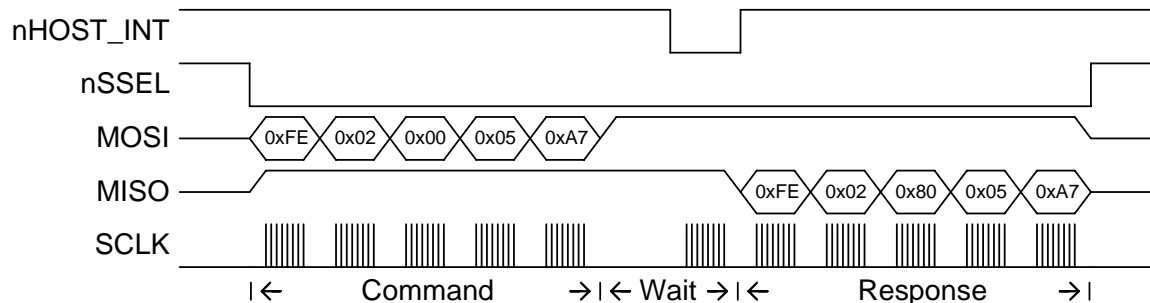

Figure 9. EmberZNet Serial Protocol Frame - NOP Command Example

1. Activate Slave Select (nSSEL).
2. Transmit the appropriate command:
 - 0xFE: SPI Byte indicating an EZSP Frame
 - 0x02: Length Byte showing the EZSP Frame is 2 bytes long
 - 0x00: EZSP Frame Control Byte indicating a command with no sleeping
 - 0x05: EZSP Frame Type Byte indicating the NOP command
 - 0xA7: Frame Terminator
3. Wait for nHOST_INT to assert.
4. Transmit and receive 0xFF until a byte other than 0xFF is received.
5. Receive response 0xFE (a byte other than 0xFF) and read the next byte for a length.
6. Stop transmitting after the number of bytes (length) is received plus the Frame Terminator.
7. Decode the response:
 - 0xFE: SPI Byte indicating an EZSP Frame
 - 0x02: Length Byte showing the EZSP Frame is 2 bytes long
 - 0x80: EZSP Frame Control Byte indicating a response with no overflow
 - 0x05: EZSP Frame Type Byte indicating the NOP response
 - 0xA7: Frame Terminator
8. Deactivate Slave Select.

5.7.3 EM260 Reset

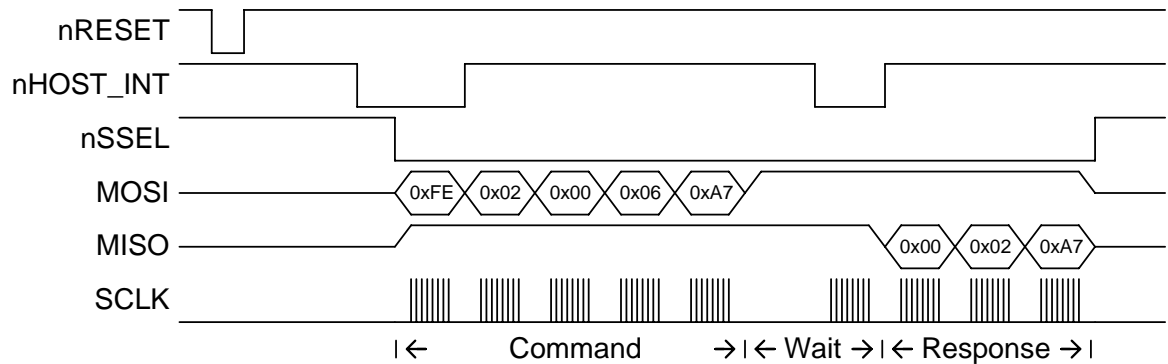

Figure 10. EM260 Reset Example

1. nHOST_INT asserts.
2. Activate Slave Select (nSSEL).
3. Transmit the command:
 - 0xFE: SPI Byte indicating an EZSP Frame
 - 0x02: Length Byte showing the EZSP Frame is 2 bytes long
 - 0x00: EZSP Frame Control Byte indicating a command with no sleeping
 - 0x06: EZSP Frame Type Byte indicating the `callback` command
 - 0xA7: Frame Terminator
4. Wait for nHOST_INT to assert.
5. Transmit and receive 0xFF until a byte other than 0xFF is received.
6. Receive response 0x00 (a byte other than 0xFF).
7. Receive the Error Byte and decode (0x02 is enumerated as `RESET_POWERON`).
8. Receive the Frame Terminator (0xA7).
9. Response 0x00 indicates the EM260 has reset and the Host should respond appropriately.
10. Deactivate Slave Select.
11. Since nHOST_INT does not assert again, there is no more data for the Host.

5.7.4 Three-Part Transaction: Wake, Get Version, Stack Status Callback

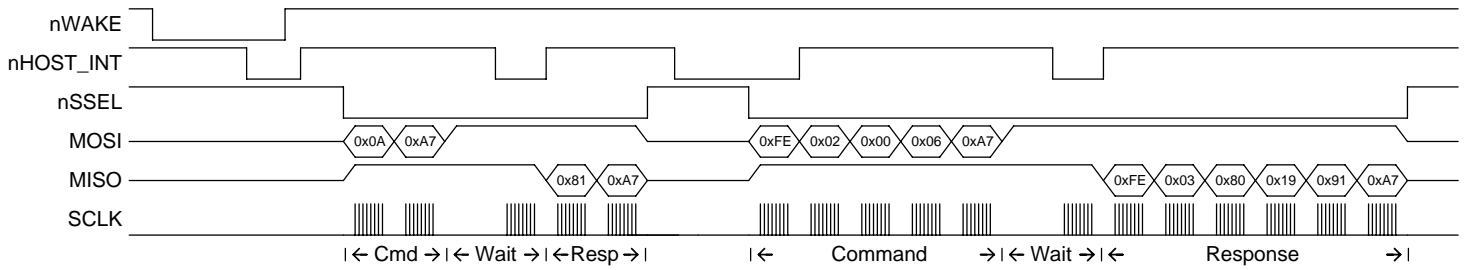

Figure 11. Timing Diagram of the Three-Part Transaction

1. Activate **nWAKE** and activate timeout timer.
2. EM260 wakes up (if not already) and enables communication.
3. **nHOST_INT** asserts, indicating the EM260 can accept commands.
4. Host sees **nHOST_INT** activation within 10ms and deactivates **nWAKE** and timeout timer.
5. **nHOST_INT** deasserts immediately after **nWAKE**.
6. Activate Slave Select.
7. Transmit the Command **0x0A** - SPI Protocol Version Request.
8. Transmit the Frame Terminator, **0xA7**.
9. Wait for **nHOST_INT** to assert.
10. Transmit and receive **0xFF** until a byte other than **0xFF** is received.
11. Receive response **0x81** (a byte other than **0xFF**), then receive the Frame Terminator, **0xA7**.
12. Bit 7 is always set and bit 6 is always cleared in the Version Response, so this is Version 1.
13. Deactivate Slave Select.
14. Host begins timing the inter-command spacing of 1ms in preparation for sending the next command.
15. **nHOST_INT** asserts shortly after deactivating Slave Select, indicating a callback.
16. Host sees **nHOST_INT**, but waits for the 1ms before responding.
17. Activate Slave Select.
18. Transmit the command:
 - **0xFE**: SPI Byte indicating an EZSP Frame
 - **0x02**: Length Byte showing the EZSP Frame is 2 bytes long
 - **0x00**: EZSP Frame Control Byte indicating a command with no sleeping
 - **0x06**: EZSP Frame Type Byte indicating the `callback` command
 - **0xA7**: Frame Terminator
19. Wait for **nHOST_INT** to assert.

20. Transmit and receive `0xFF` until a byte other than `0xFF` is received.
21. Receive response `0xFE` (a byte other than `0xFF`), read the next byte for a length.
22. Stop transmitting after the number of bytes (length) is received plus the Frame Terminator.
23. Decode the response:
 - `0xFE`: SPI Byte indicating an EZSP Frame
 - `0x03`: Length Byte showing the EZSP Frame is 3 bytes long
 - `0x80`: EZSP Frame Control Byte indicating a response with no overflow
 - `0x19`: EZSP Frame Type Byte indicating the `emberStackStatusHandler` command
 - `0x91`: `EmberStatus EMBER_NETWORK_DOWN` from `emberStackStatusHandler`
 - `0xA7` - Frame Terminator
24. Deactivate Slave Select.
25. Since `nHOST_INT` does not assert again, there is no more data for the Host.

6 EmberZNet Serial Protocol

Ember designed the EmberZNet Serial Protocol (EZSP) to be very familiar to customers who have used the EmberZNet 2.x stack API. The majority of the commands and responses are functionally identical to those found in EmberZNet 2.x. The variations are due mainly to the timing differences of running the application on a separate processor across a serial interface. Communication between the EM260 and the Host consists of a two-message transaction. The Host sends a command message to the EM260 and then the EM260 sends a response message to the Host. If the EM260 needs to communicate asynchronously with the Host, it will indicate this by using the interrupt line and then waiting for the Host to send the `callback` command.

All EZSP frames begin with a Frame Control Byte followed by a Frame ID Byte. The format of the rest of the frame depends on the frame ID. Section 6.3 Protocol Format defines the format for all the frame IDs. Most of the frames have a fixed length. A few, such as those containing application messages, are of variable length. The frame control indicates the direction of the message (command or response). For commands, the frame control also contains power management information, and for responses it also contains status information.

When a command contains an application message, the Host must supply a one-byte tag. This tag is used in future commands and responses to refer to the message. For example, when sending a message, the Host provides both the message contents and a tag. The tag is then used to report the fate of the message in a later response from the EM260.

6.1 Byte Order

All multiple octet fields are transmitted and received with the least significant octet first, also referred to as little endian. This is the same byte order convention specified by 802.15.4 and ZigBee. Note that EUI64 fields are treated as a 64-bit number and are therefore transmitted and received in little endian order. Each individual octet is transmitted most significant bit first, as shown in section 5.1, Physical Interface Configuration.

6.2 Conceptual Overview

This section provides an overview of the concepts that are specific to the EM260 or that differ from the EmberZNet 2.x stack API. The commands and responses mentioned in this overview are described in more detail later in this document.

6.2.1 Stack Configuration

The Host can use the `version` command to obtain information about the firmware running on the EM260. There are a number of configuration values that affect the behavior of the stack. The Host can read these values at any time using the `getConfigurationValue` command. After the EM260 has reset, the Host can modify any of the default values using the `setConfigurationValue` command. The Host must then provide information about the application endpoints using the `addEndpoint` command.

Table 17 gives the minimum, default and maximum values for each of the configuration values. Also listed is the RAM cost. This is the number of bytes of additional RAM required to increase the configuration value by one. Since the total amount of RAM is fixed, the additional RAM required must be made available by reducing one of the other configuration values.

Table 17. Configuration Values

Value	Min.	Def.	Max.	Units	RAM Cost	Description
EZSP_CONFIG_PACKET_BUFFER_COUNT	5	24		packet buffers	40	The number of packet buffers available to the stack.
EZSP_CONFIG_NEIGHBOR_TABLE_SIZE	8	16	16	neighbors	18	The maximum number of router neighbors the stack can keep track of. A neighbor is a node within radio range.
EZSP_CONFIG_TRANSPORT_PACKET_COUNT	0	10		messages	10	The maximum number of datagram and sequenced messages the stack can have "in-flight" at any time. Here, "in-flight" means "in the process of being either transmitted or received".
EZSP_CONFIG_BINDING_TABLE_SIZE (A)	0	8	32 + (B)	entries	3	The maximum number of bindings supported by the stack. It includes the bindings in EEPROM and in RAM.
EZSP_CONFIG_TEMPORARY_BINDING_ENTRIES (B)	0	8	(A)	entries	12	The number of binding table entries in RAM.
EZSP_CONFIG_TRANSPORT_CONNECTION_COUNT	0	0		entries	12	The number of binding table entries that can concurrently support an open sequenced connection.
EZSP_CONFIG_ROUTE_TABLE_SIZE (C)	0	16		entries	6	The maximum number of destinations to which a node can route messages. This include both messages originating at this node and those relayed for others.
EZSP_CONFIG_DISCOVERY_TABLE_SIZE	0	8		entries	10	The number of simultaneous route discoveries that a node will support.
EZSP_CONFIG_DISCOVERY_CACHE_ENDPOINTS (D)	0	4		endpoints	0	End-device child endpoints larger than this value will not have their discovery information cached by their router parent.
EZSP_CONFIG_DISCOVERY_CACHE_ENTRY_SIZE	11 + (D)	15	15	bytes	0	The size of an entry in the end device discovery cache on a router. Endpoint descriptions longer than this will not be cached.

Value	Min.	Def.	Max.	Units	RAM Cost	Description
EZSP_CONFIG_DISCOVERY_CACHE_SIZE	0	35	35	entries	0	The number of entries in the discovery cache on a router. Each end device child requires 1 + (D) entries. The cache is held in EEPROM.
EZSP_CONFIG_STACK_PROFILE	0	0			0	Specifies the stack profile.
EZSP_CONFIG_SECURITY_LEVEL	0	5	5		0	The security level used for security at the MAC and network layers. The supported values are 0 (no security) and 5 (payload is encrypted and a four-byte MIC is used for authentication).
EZSP_CONFIG_MAX_HOPS	0	10		hops	0	The maximum number of hops for a message.
EZSP_CONFIG_MAX_END_DEVICE_CHILDREN (E)	0	6	32	children	4	The maximum number of end device children that a router will support.
EZSP_CONFIG_INDIRECT_TRANSMISSION_TIMEOUT	0	300 0	3000 0	milli-seconds	0	The maximum amount of time that the MAC will hold a message for indirect transmission to a child.
EZSP_CONFIG_RESERVED_ROUTING_ENTRIES	0	0	(C)	entries	0	The number of route table entries that are reserved for temporary aggregation routes in the mesh stack.
EZSP_CONFIG_MOBILE_NODE_POLL_TIMEOUT	0	20		quarter seconds	0	The maximum amount of time that a mobile node can wait between polls. If no poll is heard within this timeout, then the parent removes the mobile node from its tables.
EZSP_CONFIG_RESERVED_MOBILE_CHILD_ENTRIES	0	0	(E)	entries	0	The number of child table entries reserved for use only by mobile nodes.
EZSP_CONFIG_HOST_RAM	0	0	255	bytes	1	The amount of RAM available for use by the Host.
EZSP_CONFIG_TX_POWER_MODE	0	0	3		0	Enables boost power mode and/or the alternate transmitter output.

6.2.2 Policy Settings

There are some situations when the EM260 must make a decision but there isn't enough time to consult with the Host. The Host can control what decision is made by setting the policy in advance. The EM260 will then make decisions according to the current policy. The Host is informed via callbacks each time a decision is

made, but by the time the news reaches the Host, it is too late to change that decision. You can change the policies at any time by using the `setPolicy` command.

A policy is used for trust center behavior, external binding modification requests, datagram replies, generating `pollHandler` callbacks, and the contents of the `unicastSent` and `messageSent` callbacks.

6.2.3 Datagram Replies

The policy for datagram replies allows the Host to decide whether it wants to supply the EM260 with a reply payload for every datagram received. If the Host sets the policy to not supply a reply, the EM260 will automatically send an empty reply (containing no payload) for every datagram received. If the Host sets the policy to supply the reply, then the EM260 will only send a reply when instructed by the Host.

If the reply does not reach the sender before the transport retry timeout expires, the sender will transmit the datagram again. The Host must process the incoming message and supply the reply quickly enough to avoid retransmission by the sender. Provided this timing constraint is met, multiple datagrams can be received before the first reply is supplied and the replies can be supplied in any order.

6.2.4 Callbacks

Asynchronous callbacks from the EM260 are sent to the Host as the response to a `callback` command. The EM260 uses the interrupt line to indicate that the Host should send a `callback` command. The EM260 will queue multiple callbacks while it waits for the Host, and each response only delivers one callback. If the EM260 receives the `callback` command when there are no pending callbacks, it will reply with the `noCallbacks` response.

6.2.5 Power Management

The EM260 will always idle its processor whenever possible. To further reduce power consumption, the EM260 can be put to sleep by the Host. In power down mode, only an external interrupt will wake the EM260. In deep sleep mode, the EM260 will use its internal timer to wake up for scheduled events. The EM260 provides two independent timers that the Host can use for any purpose, including waking up the EM260 from deep sleep mode. Timers are set using the `setTimer` command and generate `timerHandler` callbacks.

The initial Frame Control Byte of every command tells the EM260 which sleep mode to enter after it has responded to the command. Including this information in every command (instead of having a separate power management command) allows the EM260 to be put to sleep faster. If the Host needs to put the EM260 to sleep without also performing another action, the `nop` command can be used.

In deep sleep mode, the EM260 will wake up for an internal event. If the event does not produce a callback for the Host, the EM260 will go back to sleep once the event has been handled. If the event does produce a callback, the EM260 will signal the Host and remain awake waiting for the `callback` command. If the Frame Control Byte of the `callback` command specifies deep sleep mode, then the EM260 would normally go back to sleep after responding with the callback. However, if there is a second callback pending, the EM260 will remain awake waiting for another `callback` command.

To avoid disrupting the operation of the network, only put the EM260 to sleep when it is not joined to a network or when it is joined as a sleeping end device. If the EM260 is joined as a sleeping end device, then it must poll its parent in order to receive messages. The Host controls the polling behavior using the `pollForData` command. Polls are sent periodically with the interval set by the Host or a single poll can be sent. The result of every poll attempt is optionally reported using the `pollCompleteHandler` callback.

6.2.6 Tokens

Some of the non-volatile storage on the EM260 is made available for use by the Host. Up to 8 manufacturing tokens stored in the Flash Information Area can be read using the `getMfgToken` command and up to 8 tokens stored in the Simulated EEPROM can be read and written using the `setToken` and `getToken` commands. Each

token is 8 bytes. Tokens preserve their values between reboots. Refer to section 4.6.1 for a description of the Simulated EEPROM and write cycle estimates.

6.2.7 RAM

Some of the RAM on the EM260 can be reserved by the Host for its own use. The amount of space reserved is the `EZSP_CONFIG_HOST_RAM` configuration value (set using the `setConfigurationValue` command). The Host can then read and write data using the `setRam` and `getRam` commands. If the Host chooses to reserve RAM, this will reduce the number of messages and callbacks that the EM260 can buffer.

6.2.8 EM260 Status

The Frame Control Byte of every response sent by the EM260 contains two status bits:

- The overflow bit is set if the EM260 ran out of memory at any time since the previous response was sent. If this bit is set, then messages may have been lost.
- The truncated bit is set if the EM260 truncated the current response. If this bit is set, the command from the Host produced a response larger than the maximum EZSP frame length.

You can use the `nop` command to check the status of the EM260 without also performing another action.

6.2.9 Random Number Generator

The Host can obtain a random number from the EM260 using the `getRandomNumber` command. The random number is generated from analog noise in the radio and can be used to seed a random number generator on the Host.

6.3 Protocol Format

All EZSP frames begin with a Frame Control Byte. Table 18 describes the meaning of this byte for command and response frames. Table 19 describes the sleep modes, Table 20 describes the overflow status bit and Table 21 describes the truncated status bit. The second byte of all EZSP frames is the Frame ID Byte.

Table 18. Frame Control Byte

Bit	Command	Response
7 (MSB)	0	1
6	0 (reserved)	0 (reserved)
5	0 (reserved)	0 (reserved)
4	0 (reserved)	0 (reserved)
3	0 (reserved)	0 (reserved)
2	0 (reserved)	0 (reserved)
1	<code>sleepMode[1]</code>	truncated
0 (LSB)	<code>sleepMode[0]</code>	overflow

Table 19. Sleep Modes

sleepMode[1]	sleepMode[0]	Description
1	1	Reserved.
1	0	Power down.
0	1	Deep sleep.
0	0	Idle.

Table 20. Overflow Status

overflow	Description
1	The EM260 ran out of memory since the previous response.
0	No memory shortage since the previous response.

Table 21. Truncated Status

truncated	Description
1	The EM260 truncated the current response to avoid exceeding the maximum EZSP frame length.
0	The current response was not truncated.

Section 6.3.1 defines all the types used by the EM260 and section 6.3.2 defines all the structures. Section 6.3.3 enumerates all the named values for the different types. The subsequent sections list all the frames supported by the EM260, specifying the Frame ID, the command parameters and the response parameters. The list is divided into five sections:

- Section 6.3.4 lists Configuration frames.
- Section 6.3.5 lists Utilities frames.
- Section 6.3.6 lists Networking frames.
- Section 6.3.7 lists Binding frames.
- Section 6.3.8 lists Messaging frames.

Finally, section 6.3.9 provides an alphabetical list of all the frames.

6.3.1 Type Definitions

Type	Alias	Description
boolean	int8u	True or false.
EzspConfigId	int8u	Identifies a configuration value.
EzspConfigTxPowerMode	int16u	Values for EZSP_CONFIG_TX_POWER_MODE.
EzspConfigStatus	int8u	Return type for configuration commands.
EzspPolicyId	int8u	Identifies a policy.
EzspDecisionId	int8u	Identifies a policy decision.
EmberStatus	int8u	Return type for stack functions.
EmberEventUnits	int8u	Either marks an event as inactive or specifies the units for the event execution time.
EmberNodeType	int8u	The type of the node.
EmberNetworkStatus	int8u	The possible join states for a node.
EmberIncomingMessageType	int8u	Incoming message types.
EmberBindingType	int8u	Binding types.
EmberUnicastOption	int8u	Options to use when sending a unicast message.
EmberNetworkScanType	int8u	Network scan types.
EmberJoinDecision	int8u	Decision made by the trust center when a node attempts to join.
EmberNodeId	int16u	16-bit ZigBee network address.
EmberPanId	int16u	802.15.4 PAN ID.
EmberEUI64	int8u[8]	EUI 64-bit ID (an IEEE address).

6.3.2 Structure Definitions

Structure	Field	Description
EmberNetworkParameters		Network parameters.
	int16u panId	The network's PAN identifier.
	int8s radioTxPower	A power setting, in dBm.
	int8u radioChannel	A radio channel.
EmberApsFrame		ZigBee APS frame parameters.
	int16u profileId	The application profile ID that describes the format of the message.
	int8u clusterId	The cluster ID for this message.
	int8u sourceEndpoint	The source endpoint.
	int8u destinationEndpoint	The destination endpoint.
	EmberUnicastOption options	A bitmask of options.
EmberBindingTableEntry		An entry in the binding table.
	EmberBindingType type	The type of binding.
	int8u local	The endpoint on the local node.
	int8u remote	The endpoint on the remote node (specified by identifier).
	int8u clusterId	A cluster ID that matches one from the local endpoint's simple descriptor. This cluster ID is set by the provisioning application to indicate which part an endpoint's functionality is bound to this particular remote node and is used to distinguish between unicast and multicast bindings. A binding can be used to send messages with any cluster ID, not just the one listed in the binding.
	EmberEUI64 identifier	A 64-bit identifier. This is either the destination EUI64 (for unicasts) or the 64-bit group address (for multicasts).

6.3.3 Named Values

boolean		
FALSE	0x00	An alias for zero, used for clarity.
TRUE	0x01	An alias for one, used for clarity.

EzspConfigId		
EZSP_CONFIG_PACKET_BUFFER_COUNT	0x01	The number of packet buffers available to the stack.
EZSP_CONFIG_NEIGHBOR_TABLE_SIZE	0x02	The maximum number of router neighbors the stack can keep track of. A neighbor is a node within radio range.
EZSP_CONFIG_TRANSPORT_PACKET_COUNT	0x03	The maximum number of datagram and sequenced messages the stack can have 'in-flight' at any time. Here, 'in-flight' means 'in the process of being either transmitted or received'.
EZSP_CONFIG_BINDING_TABLE_SIZE	0x04	The maximum number of bindings supported by the stack. It includes the bindings in EEPROM and in RAM.
EZSP_CONFIG_TEMPORARY_BINDING_ENTRIES	0x05	The number of binding table entries in RAM.
EZSP_CONFIG_TRANSPORT_CONNECTION_COUNT	0x06	The number of binding table entries that can concurrently support an open sequenced connection.
EZSP_CONFIG_ROUTE_TABLE_SIZE	0x07	The maximum number of destinations to which a node can route messages. This include both messages originating at this node and those relayed for others.
EZSP_CONFIG_DISCOVERY_TABLE_SIZE	0x08	The number of simultaneous route discoveries that a node will support.
EZSP_CONFIG_DISCOVERY_CACHE_ENDPOINTS	0x09	End-device child endpoints larger than this value will not have their discovery information cached by their router parent.
EZSP_CONFIG_DISCOVERY_CACHE_ENTRY_SIZE	0x0A	The size of an entry in the end device discovery cache on a router. Endpoint descriptions longer than this will not be cached.
EZSP_CONFIG_DISCOVERY_CACHE_SIZE	0x0B	The number of entries in the discovery cache on a router. Each end device child requires 1 + EZSP_CONFIG_DISCOVERY_CACHE_ENDPOINTS entries. The cache is held in EEPROM.
EZSP_CONFIG_STACK_PROFILE	0x0C	Specifies the stack profile.
EZSP_CONFIG_SECURITY_LEVEL	0x0D	The security level used for security at the MAC and network layers. The supported values are 0 (no security) and 5 (payload is encrypted and a four-byte MIC is used for authentication).
EZSP_CONFIG_MAX_HOPS	0x10	The maximum number of hops for a message.
EZSP_CONFIG_MAX_END_DEVICE_CHILDREN	0x11	The maximum number of end device children that a router will support.
EZSP_CONFIG_INDIRECT_TRANSMISSION_TIMEOUT	0x12	The maximum amount of time that the MAC will hold a message for indirect transmission to a child.
EZSP_CONFIG_RESERVED_ROUTING_ENTRIES	0x13	The number of route table entries that are reserved for temporary aggregation routes in the mesh stack.
EZSP_CONFIG_MOBILE_NODE_POLL_TIMEOUT	0x14	The maximum amount of time that a mobile node can wait between polls. If no poll is heard within this timeout, then the parent removes the mobile node from its tables.
EZSP_CONFIG_RESERVED_MOBILE_CHILD_ENTRIES	0x15	The number of child table entries reserved for use only by mobile nodes.
EZSP_CONFIG_HOST_RAM	0x16	The amount of RAM available for use by the Host.
EZSP_CONFIG_TX_POWER_MODE	0x17	Enables boost power mode and/or the alternate transmitter output.

EzspConfigTxPowerMode		
EMBER_TX_POWER_MODE_DEFAULT	0x00	Normal power mode and bi-directional RF transmitter output.
EMBER_TX_POWER_MODE_BOOST	0x01	Enable boost power mode. This is a high performance radio mode which offers increased receive sensitivity and transmit power at the cost of an increase in power consumption.
EMBER_TX_POWER_MODE_ALTERNATE	0x02	Enable the alternate transmitter output. This allows for simplified connection to an external power amplifier via the RF_TX_ALT_P and RF_TX_ALT_N pins.
EMBER_TX_POWER_MODE_BOOST_AND_ALTERNATE	0x03	Enable both boost mode and the alternate transmitter output.

EzspConfigStatus		
EZSP_CONFIG_SUCCESS	0x00	The command was successful.
EZSP_CONFIG_OUT_OF_MEMORY	0x01	Insufficient memory was available.
EZSP_CONFIG_INVALID_VALUE	0x02	The value was out of bounds.
EZSP_CONFIG_INVALID_TAG	0x03	The configuration tag was not recognized.
EZSP_CONFIG_INVALID_CALL	0x04	Configuration values can no longer be modified.

EzspPolicyId		
EZSP_TRUST_CENTER_POLICY	0x00	Controls trust center behavior.
EZSP_BINDING_MODIFICATION_POLICY	0x01	Controls how external binding modification requests are handled.
EZSP_DATAGRAM_REPLIES_POLICY	0x02	Controls whether the Host supplies datagram replies.
EZSP_POLL_HANDLER_POLICY	0x03	Controls whether <code>pollHandler</code> callbacks are generated.
EZSP_MESSAGE_CONTENTS_IN_CALLBACK_POLICY	0x04	Controls whether the message contents are included in <code>unicastSent</code> and <code>messageSent</code> callbacks.

EM260

EzspDecisionId		
EZSP_ALLOW_SECURE_JOINS_ONLY	0x00	EZSP_TRUST_CENTER_POLICY default decision. Only allow nodes that are joining securely using the network key to join.
EZSP_ALLOW_ALL_JOINS	0x01	EZSP_TRUST_CENTER_POLICY decision. Allow all nodes to join, sending the key to nodes that are not joining securely.
EZSP_DISALLOW_ALL_JOINS	0x02	EZSP_TRUST_CENTER_POLICY decision. Reject all join attempts.
EZSP_ASK_TRUST_CENTER	0x03	EZSP_TRUST_CENTER_POLICY decision. Forward the request to the trust center (this value should not be used for the trust center itself).
EZSP_DISALLOW_BINDING_MODIFICATION	0x10	EZSP_BINDING_MODIFICATION_POLICY default decision. Do not allow the local binding table to be changed by remote nodes.
EZSP_ALLOW_BINDING_MODIFICATION	0x11	EZSP_BINDING_MODIFICATION_POLICY decision. Allow remote nodes to change the local binding table.
EZSP_HOST_WILL_NOT_SUPPLY_REPLY	0x20	EZSP_DATAGRAM_REPLIES_POLICY default decision. The EM260 will automatically send an empty reply (containing no payload) for every datagram received.
EZSP_HOST_WILL_SUPPLY_REPLY	0x21	EZSP_DATAGRAM_REPLIES_POLICY decision. The EM260 will only send a reply if it receives a <code>sendReply</code> command from the Host.
EZSP_POLL_HANDLER_IGNORE	0x30	EZSP_POLL_HANDLER_POLICY default decision. Do not inform the Host when a child polls.
EZSP_POLL_HANDLER_CALLBACK	0x31	EZSP_POLL_HANDLER_POLICY decision. Generate a <code>pollHandler</code> callback when a child polls.
EZSP_MESSAGE_TAG_ONLY_IN_CALLBACK	0x40	EZSP_MESSAGE_CONTENTS_IN_CALLBACK_POLICY default decision. Include only the message tag in <code>unicastSent</code> and <code>messageSent</code> callbacks.
EZSP_MESSAGE_TAG_AND_CONTENTS_IN_CALLBACK	0x41	EZSP_MESSAGE_CONTENTS_IN_CALLBACK_POLICY decision. Include both the message tag and the message contents in <code>unicastSent</code> and <code>messageSent</code> callbacks.

EmberStatus		
EMBER_SUCCESS	0x00	Generic 'no error' message.
EMBER_ERR_FATAL	0x01	Generic 'fatal error' message.
EMBER_EEPROM_MFG_STACK_VERSION_MISMATCH	0x04	Manufacturing and stack token format in non-volatile memory is different than what the stack expects (returned at initialization).
EMBER_INCOMPATIBLE_STATIC_MEMORY_DEFINITIONS	0x05	Static memory definitions in ember-static-memory.h are incompatible with this stack version.
EMBER_EEPROM_MFG_VERSION_MISMATCH	0x06	Manufacturing token format in non-volatile memory is different than what the stack expects (returned at initialization).
EMBER_EEPROM_STACK_VERSION_MISMATCH	0x07	Stack token format in non-volatile memory is different than what the stack expects (returned at initialization).
EMBER_NO_BUFFERS	0x18	There are no more buffers.
EMBER_SERIAL_INVALID_BAUD_RATE	0x20	Specified an invalid baud rate.
EMBER_SERIAL_INVALID_PORT	0x21	Specified an invalid serial port.
EMBER_SERIAL_TX_OVERFLOW	0x22	Tried to send too much data.
EMBER_SERIAL_RX_OVERFLOW	0x23	There was not enough space to store a received character and the character was dropped.
EMBER_SERIAL_RX_FRAME_ERROR	0x24	Detected a UART framing error.
EMBER_SERIAL_RX_PARITY_ERROR	0x25	Detected a UART parity error.
EMBER_SERIAL_RX_EMPTY	0x26	There is no received data to process.
EMBER_SERIAL_RX_OVERRUN_ERROR	0x27	Receive interrupt was not handled in time, and a character was dropped.
EMBER_MAC_TRANSMIT_QUEUE_FULL	0x39	MAC transmit queue is full.
EMBER_MAC_UNKNOWN_HEADER_TYPE	0x3A	MAC header FCR error on receive.
EMBER_MAC_SCANNING	0x3D	MAC can't complete this task because it is scanning.
EMBER_MAC_NO_DATA	0x31	No pending data exists for device doing a data poll.
EMBER_MAC_JOINED_NETWORK	0x32	Attempt to scan when we are joined to a network.
EMBER_MAC_BAD_SCAN_DURATION	0x33	Scan duration must be 0 to 14 inclusive. Attempt was made to scan with an incorrect duration value.
EMBER_MAC_INCORRECT_SCAN_TYPE	0x34	emberStartScan was called with an incorrect scan type.
EMBER_MAC_INVALID_CHANNEL_MASK	0x35	emberStartScan was called with an invalid channel mask.
EMBER_MAC_COMMAND_TRANSMIT_FAILURE	0x36	Failed to scan current channel because we were unable to transmit the relevant MAC command.
EMBER_MAC_NO_ACK_RECEIVED	0x40	We expected to receive an ACK following the transmission, but the MAC level ACK was never received.
EMBER_MAC_INDIRECT_TIMEOUT	0x42	Indirect data message timed out before polled.

EmberStatus		
EMBER_SIM_EEPROM_ERASE_PAGE_GREEN	0x43	Simulated EEPROM is telling the application that there is at least one flash page to be erased. GREEN status means the current page has not filled above the <code>ERASE_CRITICAL_THRESHOLD</code> . The application should call the function <code>halSimEepromErasePage()</code> when it can to erase a page.
EMBER_SIM_EEPROM_ERASE_PAGE_RED	0x44	Simulated EEPROM is telling the application that there is at least one flash page to be erased. RED status means the current page has filled above the <code>ERASE_CRITICAL_THRESHOLD</code> . Due to the shrinking availability of write space, there is a danger of data loss. The application must call the function <code>halSimEepromErasePage()</code> as soon as possible to erase a page.
EMBER_SIM_EEPROM_FULL	0x45	Simulated EEPROM has run out of room to write any new data and the data trying to be set has been lost. This error code is the result of ignoring the <code>SIM_EEPROM_ERASE_PAGE_RED</code> error code. The application must call the function <code>halSimEepromErasePage()</code> to make room for any further calls to set a token.
EMBER_SIM_EEPROM_FLASH_WRITE_FAILED	0x46	A fatal error has occurred while trying to write data to the Flash and the write verification has failed. The data in the flash cannot be trusted after this error, and it is possible this error is the result of exceeding the life cycles of the flash.
EMBER_SIM_EEPROM_INIT_1_FAILED	0x47	Attempt 1 to initialize the Simulated EEPROM has failed. This failure means the information already stored in Flash (or a lack thereof), is fatally incompatible with the token information compiled into the code image being run.
EMBER_SIM_EEPROM_INIT_2_FAILED	0x48	Attempt 2 to initialize the Simulated EEPROM has failed. This failure means Attempt 1 failed, and the token system failed to properly reload default tokens and reset the Simulated EEPROM.
EMBER_SIM_EEPROM_INIT_3_FAILED	0x49	Attempt 3 to initialize the Simulated EEPROM has failed. This failure means one or both of the tokens <code>TOKEN_MFG_NVDATA_VERSION</code> or <code>TOKEN_STACK_NVDATA_VERSION</code> were incorrect and the token system failed to properly reload default tokens and reset the Simulated EEPROM.
EMBER_ERR_TOKEN_UNKNOWN	0x4B	An unknown flash token was specified.
EMBER_ERR_TOKEN_EXISTS	0x4C	Could not create new flash token because it already exists.
EMBER_ERR_TOKEN_INVALID_SIZE	0x4D	An incorrect size was specified when retrieving token data.
EMBER_ERR_TOKEN_READ_ONLY	0x4E	Couldn't write token because it is marked read-only.
EMBER_ERR_BOOTLOADER_TRAP_TABLE_BAD	0x58	Bootloader received an invalid message (failed attempt to go into bootloader).
EMBER_ERR_BOOTLOADER_TRAP_UNKNOWN	0x59	Bootloader received an invalid message (failed attempt to go into bootloader).
EMBER_ERR_BOOTLOADER_NO_IMAGE	0x5A	Bootloader cannot complete the bootload operation because either an image was not found or the image exceeded memory bounds.

EmberStatus		
EMBER_TOO_MANY_CONNECTIONS	0x60	EMBER_TRANSPORT_CONNECTION_COUNT limit has been reached.
EMBER_CONNECTION_OPEN	0x61	A connection has either been opened or is already open.
EMBER_CONNECTION_FAILED	0x63	A connection experienced a catastrophic error. The connection is now closed and messages may have been lost.
EMBER_CONNECTION_CLOSED	0x64	Transport layer successfully closed a connection.
EMBER_CONNECTION_CLOSING	0x65	Transport layer is in process of closing a connection (waiting for a response from the remote device).
EMBER_DELIVERY_FAILED	0x66	Transport layer attempted to send or deliver a message, but it failed.
EMBER_BINDING_INDEX_OUT_OF_RANGE	0x69	This binding index is out of range of the current binding table.
EMBER_INVALID_BINDING_TERMINAL	0x6B	Could not set or find a binding index given the specified terminal.
EMBER_INVALID_BINDING_INDEX	0x6C	An invalid binding table index was given to a function.
EMBER_TERMINAL_HAS_MULTIPLE_BINDINGS	0x6F	Multiple binding table entries were found for the specified terminal.
EMBER_INVALID_CALL	0x70	API call is not allowed given the current state of the stack (for example, opening a connection from a sleepy node.).
EMBER_COST_NOT_KNOWN	0x71	Link cost to a node is not known.
EMBER_MAX_MESSAGE_LIMIT_REACHED	0x72	Maximum number of in-flight messages (such as EMBER_TRANSPORT_PACKET_COUNT) has been reached.
EMBER_CONNECTION_NOT_YET_OPEN	0x73	A connection is not open yet.
EMBER_MESSAGE_TOO_LONG	0x74	Message to be transmitted is too big to fit into a single over-the-air packet.
EMBER_BINDING_IS_ACTIVE	0x75	Application is trying to delete or overwrite a binding that is in use.
EMBER_EUI64_NOT_AVAILABLE	0x76	EUI64 is not available in the current packet.
EMBER_INCOMING_SEQUENCED_MESSAGES_LOST	0x77	One or more sequenced messages failed to be received.
EMBER_ADC_CONVERSION_DONE	0x80	Conversion is complete.
EMBER_ADC_CONVERSION_BUSY	0x81	Conversion cannot be done because a request is being processed.
EMBER_ADC_CONVERSION_DEFERRED	0x82	Conversion is deferred until the current request has been processed.
EMBER_ADC_NO_CONVERSION_PENDING	0x84	No results are pending.
EMBER_SLEEP_INTERRUPTED	0x85	Sleeping (for a duration) has been abnormally interrupted and exited prematurely.
EMBER_PHY_TX_UNDERFLOW	0x88	Transmit hardware buffer underflowed.
EMBER_PHY_TX_INCOMPLETE	0x89	Transmit hardware did not finish transmitting a packet.
EMBER_PHY_INVALID_CHANNEL	0x8A	An unsupported channel setting was specified.
EMBER_PHY_INVALID_POWER	0x8B	An unsupported power setting was specified.

EmberStatus		
EMBER_PHY_TX_BUSY	0x8C	Packet cannot be transmitted because the physical MAC layer is currently transmitting a packet. (This is used for the MAC backoff algorithm.)
EMBER_PHY_UNKNOWN_RADIO_TYPE	0x8D	The software installed on the hardware doesn't recognize the hardware radio type.
EMBER_PHY_OSCILLATOR_CHECK_FAILED	0x8E	The software installed on the hardware doesn't recognize the hardware radio type.
EMBER_PHY_PARTIAL_PACKET	0x8F	PHY did not receive the entire packet it was expecting from the radio.
EMBER_NETWORK_UP	0x90	Stack software has completed initialization and is ready to send and receive packets over the air.
EMBER_NETWORK_DOWN	0x91	Network is not operating.
EMBER_NETWORK_PENDING_ACTIVITY	0x92	Network has activity pending and should not be shut down.
EMBER_NOT_JOINED	0x93	Node has not joined a network.
EMBER_JOIN_FAILED	0x94	An attempt to join a network failed.
EMBER_INVALID_SECURITY_LEVEL	0x95	The chosen security level (the value of <code>EMBER_SECURITY_LEVEL</code>) is not supported by the stack.
EMBER_MOVE_FAILED	0x96	After moving, a mobile node's attempt to re-establish contact with the network failed.
EMBER_NETWORK_BUSY	0xA1	A message cannot be sent because the network is currently overloaded.
EMBER_NODEID_INVALID	0xA2	A datagram was sent to a node and the EUI64 address in the datagram did not match the node's EUI64 address. The NodeId was invalid.
EMBER_INVALID_ENDPOINT	0xA3	The application tried to send a message using an endpoint that it has not defined.
EMBER_BINDING_HAS_CHANGED	0xA4	The application tried to use a binding that has been remotely modified and the change has not yet been reported to the application.
EMBER_STACK_AND_HARDWARE_MISMATCH	0xB0	A critical and fatal error indicating that the version of the stack trying to run does not match with the chip it is running on. The software (stack) on the chip must be replaced with software that is compatible with the chip.

EmberEventUnits		
EMBER_EVENT_INACTIVE	0x00	Event is not scheduled to run.
EMBER_EVENT_MS_TIME	0x01	Execution time is in approximate milliseconds.
EMBER_EVENT_QS_TIME	0x02	Execution time is in 'binary' quarter seconds (256 approximate milliseconds each).
EMBER_EVENT_MINUTE_TIME	0x03	Execution time is in 'binary' minutes (65536 approximate milliseconds each).

EmberNodeType		
EMBER_COORDINATOR	0x01	Will relay messages and can act as a parent to other nodes.
EMBER_ROUTER	0x02	Will relay messages and can act as a parent to other nodes.
EMBER_END_DEVICE	0x03	Communicates only with its parent and will not relay messages.
EMBER_SLEEPY_END_DEVICE	0x04	An end device whose radio can be turned off to save power. The application must poll to receive messages.
EMBER_MOBILE_END_DEVICE	0x05	A sleepy end device that can move through the network.

EmberNetworkStatus		
EMBER_NO_NETWORK	0x00	The node is not associated with a network in any way.
EMBER_JOINING_NETWORK	0x01	The node is currently attempting to join a network.
EMBER_JOINED_NETWORK	0x02	The node is joined to a network.
EMBER_JOINED_NETWORK_NO_PARENT	0x03	The node is an end device joined to a network but its parent is not responding.
EMBER_LEAVING_NETWORK	0x04	The node is in the process of leaving its current network.

EmberIncomingMessageType		
EMBER_INCOMING_DATAGRAM	0x00	Datagram.
EMBER_INCOMING_DATAGRAM_REPLY	0x01	Datagram reply.
EMBER_INCOMING_SEQUENCED	0x02	Sequenced message.
EMBER_INCOMING_MULTICAST	0x03	Multicast.
EMBER_INCOMING_SHARED_MULTICAST	0x04	Shared multicast.
EMBER_INCOMING_MULTICAST_LOOPBACK	0x05	Multicast loopback.
333EMBER_INCOMING_UNICAST	0x06	Unicast.
EMBER_INCOMING_BROADCAST	0x07	Broadcast.

EmberBindingType		
EMBER_UNUSED_BINDING	0x00	A binding that is currently not in use.
EMBER_UNICAST_BINDING	0x01	A unicast binding whose 64-bit identifier is the destination EUI64.
EMBER_AGGREGATION_BINDING	0x02	A unicast binding whose 64-bit identifier is the aggregator EUI64.
EMBER_MULTICAST_BINDING	0x03	A multicast binding whose 64-bit identifier is the group address. A multicast binding can be used to send messages to the group and to receive messages sent to the group.

EmberUnicastOption		
EMBER_UNICAST_OPTION_NONE	0x00	No options.
EMBER_UNICAST_OPTION_APS_INDIRECT	0x04	Reserved.
EMBER_UNICAST_OPTION_HAVE_SOURCE	0x10	Reserved.
EMBER_UNICAST_OPTION_APS_RETRY	0x40	Resend the message using the APS retry mechanism.
EMBER_UNICAST_OPTION_ENABLE_ROUTE_DISCOVERY	0x80	Causes a route discovery to be initiated if no route to the destination is known.
EMBER_UNICAST_OPTION_FORCE_ROUTE_DISCOVERY	0x20	Causes a route discovery to be initiated even if one is known.
EMBER_UNICAST_OPTION_POLL_RESPONSE	0x01	Reserved.

EmberNetworkScanType		
EMBER_ENERGY_SCAN	0x00	An energy scan scans each channel for its RSSI value.
EMBER_ACTIVE_SCAN	0x01	An active scan scans each channel for available networks.

EmberJoinDecision		
EMBER_HAS_KEY	0x00	Allow the node to join. The node has the key.
EMBER_SEND_KEY	0x01	Allow the node to join. Send the key to the node.
EMBER_DENY_JOIN	0x02	Deny join.
EMBER_ASK_TRUST_CENTER	0x03	Ask the trust center.

6.3.4 Configuration Frames

Name: version	ID: 0x00
Description: The command allows the Host to specify the desired EZSP version. This document describes version 1 of the protocol. The response provides information about the firmware running on the EM260.	
Command Parameters:	
int8u desiredProtocolVersion	The EZSP version the Host wishes to use.
Response Parameters:	
int8u protocolVersion	The EZSP version the EM260 is using. If the EM260 does not support the version requested by the Host, it will use the highest version it does support.
int8u stackType	The type of stack running on the EM260. The available EZSP commands and their parameters depend on the stack type. The mesh stack is type 2.
int16u stackVersion	The version number of the stack.

Name: getConfigurationValue	ID: 0x52
Description: Reads a configuration value from the EM260.	
Command Parameters:	
EzspConfigId configId	Identifies which configuration value to read.
Response Parameters:	
EzspConfigStatus status	EZSP_CONFIG_SUCCESS if the value was read successfully, EZSP_CONFIG_INVALID_ID if the EM260 does not recognize configId.
int16u value	The configuration value.

Name: setConfigurationValue	ID: 0x53
Description: Writes a configuration value to the EM260. Configuration values can be modified by the Host after the EM260 has reset. After the stack status changes to EMBER_NETWORK_UP, configuration values can no longer be modified and this command will respond with EZSP_CONFIG_INVALID_CALL.	
Command Parameters:	
EzspConfigId configId	Identifies which configuration value to change.
int16u value	The new configuration value.
Response Parameters:	
EzspConfigStatus status	EZSP_CONFIG_SUCCESS if the configuration value was changed, EZSP_CONFIG_OUT_OF_MEMORY if the new value exceeded the available memory, EZSP_CONFIG_INVALID_VALUE if the new value was out of bounds, EZSP_CONFIG_INVALID_ID if the EM260 does not recognize configId, EZSP_CONFIG_INVALID_CALL if configuration values can no longer be modified.

EM260

Name: addEndpoint	ID: 0x02
Description: Configures endpoint information on the EM260. The EM260 does not remember these settings after a reset. Endpoints can be added by the Host after the EM260 has reset. After the stack status changes to EMBER_NETWORK_UP, endpoints can no longer be added and this command will respond with EZSP_CONFIG_INVALID_CALL.	
Command Parameters:	
int8u endpoint	The application endpoint to be added.
int16u profileId	The endpoint's application profile.
int16u deviceId	The endpoint's device ID within the application profile.
int8u appFlags	The device version and flags indicating description availability.
int8u inputClusterCount	The number of input clusters.
int8u outputClusterCount	The number of output clusters.
int8u[] inputClusterList	Input cluster IDs the endpoint will accept.
int8u[] outputClusterList	Output cluster IDs the endpoint may send.
Response Parameters:	
EzspConfigStatus status	EZSP_CONFIG_SUCCESS if the endpoint was added, EZSP_CONFIG_OUT_OF_MEMORY if there is not enough memory available to add the endpoint, EZSP_CONFIG_INVALID_VALUE if the endpoint already exists, EZSP_CONFIG_INVALID_CALL if endpoints can no longer be added.

Name: setPolicy	ID: 0x55
Description: Allows the Host to change the policies used by the EM260 to make fast decisions.	
Command Parameters:	
EzspPolicyId policyId	Identifies which policy to modify.
EzspDecisionId decisionId	The new decision for the specified policy.
Response Parameters:	
EzspConfigStatus status	EZSP_CONFIG_SUCCESS if the policy was changed, EZSP_CONFIG_INVALID_ID if the EM260 does not recognize <code>policyId</code> .

Name: getPolicy	ID: 0x56
Description: Allows the Host to read the policies used by the EM260 to make fast decisions.	
Command Parameters:	
EzspPolicyId policyId	Identifies which policy to read.
Response Parameters:	
EzspConfigStatus status	EZSP_CONFIG_SUCCESS if the policy was read successfully, EZSP_CONFIG_INVALID_ID if the EM260 does not recognize <code>policyId</code> .
EzspDecisionId decisionId	The current decision for the specified policy.

6.3.5 Utilities Frames

Name: nop	ID: 0x05
Description: A transaction which does nothing. The Host can use this to set the sleep mode or to check the status of the EM260.	
Command Parameters: None	
Response Parameters: None	

Name: invalidCommand	ID: 0x58
Description: Indicates that the EM260 received a command containing an unsupported frame ID.	
This frame is a response to an invalid command.	
Response Parameters: None	

Name: callback	ID: 0x06
Description: Allows the EM260 to respond with a pending callback.	
Command Parameters: None	
The response to this command can be any of the callback responses.	

Name: noCallbacks	ID: 0x07
Description: Indicates that there are currently no pending callbacks.	
This frame is a response to the <code>callback</code> command.	
Response Parameters: None	

Name: reset	ID: 0x08
Description: Allows the Host to reset the EM260.	
Command Parameters: None	
Response Parameters: None	

Name: setToken	ID: 0x09
Description: Sets a token (8 bytes of non-volatile storage) in the Simulated EEPROM of the EM260.	
Command Parameters:	
int8u tokenId	Which token to set (0 to 7).
int8u[8] tokenData	The data to write to the token.
Response Parameters:	
EmberStatus status	An EmberStatus value indicating success or the reason for failure.

EM260

Name: getToken	ID: 0x0A
Description: Retrieves a token (8 bytes of non-volatile storage) from the Simulated EEPROM of the EM260.	
Command Parameters:	
int8u tokenId	Which token to read (0 to 7).
Response Parameters:	
EmberStatus status	An EmberStatus value indicating success or the reason for failure.
int8u[8] tokenData	The contents of the token.

Name: getMfgToken	ID: 0x0B
Description: Retrieves a manufacturing token (8 bytes of non-volatile storage) from the Flash Information Area of the EM260.	
Command Parameters:	
int8u tokenId	Which manufacturing token to read (0 to 7).
Response Parameters:	
EmberStatus status	An EmberStatus value indicating success or the reason for failure.
int8u[8] tokenData	The contents of the manufacturing token.

Name: setRam	ID: 0x46
Description: Writes data supplied by the Host to RAM in the EM260. The amount of RAM available for use by the Host must be set using the <code>setConfigurationValue</code> command.	
Command Parameters:	
int8u startIndex	The location to start writing the data.
int8u dataLength	The length of the <code>data</code> parameter in bytes.
int8u[] data	The data to write to RAM.
Response Parameters:	
EmberStatus status	An EmberStatus value indicating success or the reason for failure.

Name: getRam	ID: 0x47
Description: Reads data from RAM in the EM260 and returns it to the Host.	
Command Parameters:	
int8u startIndex	The location to start reading the data.
int8u length	The number of bytes to read.
Response Parameters:	
EmberStatus status	An EmberStatus value indicating success or the reason for failure.
int8u dataLength	The length of the <code>data</code> parameter in bytes.
int8u[] data	The data read from RAM.

Name: getRandomNumber		ID: 0x49
Description: Returns a random number, generated using noise from the radio.		
Command Parameters: None		
Response Parameters:		
EmberStatus status	An EmberStatus value indicating success or the reason for failure.	
int16u value	If status is EMBER_SUCCESS, a random number. Otherwise, zero.	

Name: getMillisecondTime		ID: 0x0D
Description: Returns the current time in milliseconds according to the EM260's internal clock.		
Command Parameters: None		
Response Parameters:		
int32u time	The current time in milliseconds.	

Name: setTimer		ID: 0x0E
Description: Sets a timer on the EM260. There are 2 independent timers available for use by the Host. A timer can be cancelled by setting <code>time</code> to 0 or <code>units</code> to EMBER_EVENT_INACTIVE.		
Command Parameters:		
int8u timerId	Which timer to set (0 or 1).	
int16u time	The delay before the <code>timerHandler</code> callback will be generated. Note that the timer clock is free running and is not synchronized with this command. This means that the actual delay will be between <code>time</code> and <code>(time - 1)</code> . The maximum delay is 32767.	
EmberEventUnits units	The units for <code>time</code> .	
boolean repeat	If true, a <code>timerHandler</code> callback will be generated repeatedly. If false, only a single <code>timerHandler</code> callback will be generated.	
Response Parameters:		
EmberStatus status	An EmberStatus value indicating success or the reason for failure.	

EM260

Name: getTimer	ID: 0x4E
Description: Gets information about a timer. The Host can use this command to find out how much longer it will be before a previously set timer will generate a callback.	
Command Parameters:	
int8u timerId	Which timer to get information about (0 or 1).
Response Parameters:	
int16u time	The delay before the <code>timerHandler</code> callback will be generated.
EmberEventUnits units	The units for <code>time</code> .
boolean repeat	True if a <code>timerHandler</code> callback will be generated repeatedly. False if only a single <code>timerHandler</code> callback will be generated.

Name: timerHandler	ID: 0x0F
Description: A callback from the timer.	
This frame is a response to the <code>callback</code> command.	
Response Parameters:	
int8u timerId	Which timer generated the callback (0 or 1).

Name: serialWrite	ID: 0x10
Description: Sends a serial message from the Host to the InSight debug system via the EM260.	
Command Parameters:	
int8u messageLength	The length of the <code>messageContents</code> parameter in bytes.
int8u[] messageContents	The serial message.
Response Parameters:	
EmberStatus status	An <code>EmberStatus</code> value indicating success or the reason for failure.

Name: serialRead	ID: 0x11
Description: Allows the Host to read a serial message from the InSight debug system via the EM260.	
Command Parameters:	
int8u length	The maximum number of bytes to read.
Response Parameters:	
int8u messageLength	The length of the <code>messageContents</code> parameter in bytes.
int8u[] messageContents	The serial message.

Name: debugWrite	ID: 0x12
Description: Sends a debug message from the Host to the InSight debug system via the EM260.	
Command Parameters:	
boolean binaryMessage	TRUE if the message should be interpreted as binary data, FALSE if the message should be interpreted as ASCII text.
int8u messageLength	The length of the <code>messageContents</code> parameter in bytes.
int8u[] messageContents	The binary message.
Response Parameters:	
EmberStatus status	An EmberStatus value indicating success or the reason for failure.

Name: debugHandler	ID: 0x13
Description: Delivers a binary message from the InSight debug system to the Host via the EM260.	
This frame is a response to the <code>callback</code> command.	
Response Parameters:	
int8u messageLength	The length of the <code>messageContents</code> parameter in bytes.
int8u[] messageContents	The binary message.

6.3.6 Networking Frames

Name: setEncryptionKey	ID: 0x14
Description: Sets the encryption key used to encrypt and decrypt radio messages. This function does not work if the stack is already associated with a network.	
Command Parameters:	
int8u[16] key	A pointer to a 16-byte encryption key.
int8u keySequenceNumber	The sequence number associated with this key.
Response Parameters:	
EmberStatus status	An EmberStatus value indicating success or the reason for failure.

Name: setManufacturerCode	ID: 0x15
Description: Sets the manufacturer code to the specified value. The manufacturer code is one of the fields of the node descriptor.	
Command Parameters:	
int16u code	The manufacturer code for the local node.
Response Parameters: None	

Name: startScan	ID: 0x1A
Description: This function will start a scan.	
Command Parameters:	
EmberNetworkScanType scanType	Indicates the type of scan to be performed. Possible values: EMBER_ENERGY_SCAN, EMBER_ACTIVE_SCAN.
int32u channelMask	Bits set as 1 indicate that this particular channel should be scanned. Bits set to 0 indicate that this particular channel should not be scanned. For example, a channelMask value of 0x00000001 would indicate that only channel 0 should be scanned. Valid channels range from 11 to 26 inclusive. This translates to a channel mask value of 0x07FFF800.
int8u duration	Sets the exponent of the number of scan periods, where a scan period is 960 symbols. The scan will occur for $((2^{\text{duration}}) + 1)$ scan periods.
Response Parameters:	
EmberStatus status	EMBER_SUCCESS signals that the scan successfully started. Possible error responses and their meanings: EMBER_MAC_SCANNING, we are already scanning; EMBER_MAC_JOINED_NETWORK, we are currently joined to a network and can not begin a scan; EMBER_MAC_BAD_SCAN_DURATION, we have set a duration value that is not 0..14 inclusive; EMBER_MAC_INCORRECT_SCAN_TYPE, we have requested an undefined scanning type; EMBER_MAC_INVALID_CHANNEL_MASK, our channel mask did not specify any valid channels.

Name: energyScanResultHandler	ID: 0x48
Description: Reports the result of an energy scan for a single channel. The scan is not complete until the <code>scanCompleteHandler</code> callback is called.	
This frame is a response to the <code>callback</code> command.	
Response Parameters:	
int8u channel	The 802.15.4 channel number that was scanned.
int8u maxRssiValue	The maximum RSSI value found on the channel.

Name: networkFoundHandler	ID: 0x1B
Description: Reports that a network was found, and gives the network parameters useful for deciding which network to join.	
This frame is a response to the <code>callback</code> command.	
Response Parameters:	
int8u channel	The 802.15.4 channel number on which the current network was found.
int16u panId	The PAN ID of the current network.
boolean expectingJoin	Whether the node that generated this beacon is allowing additional children to join to its network.
int8u stackProfile	The ZigBee profile number of the current network.

EM260

Name: scanCompleteHandler	ID: 0x1C
Description: Returns the status of the current scan. EMBER_SUCCESS signals that the scan has completed. Other error conditions signify a failure to scan on the channel specified.	
This frame is a response to the <code>callback</code> command.	
Response Parameters:	
int8u channel	The channel on which the current error occurred. Undefined for the case of EMBER_SUCCESS.
EmberStatus status	The error condition that occurred on the current channel. Value will be EMBER_SUCCESS when the scan has completed.

Name: stopScan	ID: 0x1D
Description: Terminates a scan in progress.	
Command Parameters: None	
Response Parameters:	
EmberStatus status	An EmberStatus value indicating success or the reason for failure.

Name: formNetwork	ID: 0x1E
Description: Forms a new network by becoming the coordinator.	
Command Parameters:	
EmberNetworkParameters parameters	Specification of the new network.
Response Parameters:	
EmberStatus status	An EmberStatus value indicating success or the reason for failure.

Name: joinNetwork	ID: 0x1F
Description: Causes the stack to associate with the network using the specified network parameters. It can take several seconds for the stack to associate with the local network. Do not send messages until the <code>stackStatusHandler</code> callback informs you that the stack is up.	
Command Parameters:	
EmberNodeType nodeType	Specification of the role that this node will have in the network. This role must not be EMBER_COORDINATOR. To be a coordinator, use the <code>formNetwork</code> command.
EmberNetworkParameters parameters	Specification of the network with which the node should associate.
boolean joinSecurely	If true, the node uses the current key to secure messages during the joining process. The proper value for secured networks depends upon their configuration. Some networks use unsecured joining and distribute the key from the coordinator. Other networks require secure joining and accept only nodes that know the correct key. This value has no effect if the security level is 0.
Response Parameters:	
EmberStatus status	An EmberStatus value indicating success or the reason for failure.

Name: scanAndFormNetwork	ID: 0x4F
<p>Description: Scan for an available channel and PAN ID then form a network. This performs the following actions: 1. Performs an energy scan on the indicated channels and randomly chooses one from amongst those with the least average energy. 2. Randomly picks a PAN ID that does not appear during an active scan on the chosen channel. 3. Forms a network using the chosen channel and PAN ID. If any errors occur the status code is passed to the <code>scanErrorHandler</code> callback and no network is formed. Success is indicated when the <code>stackStatusHandler</code> callback is invoked with the <code>EMBER_NETWORK_UP</code> status value.</p>	
<p>Command Parameters:</p>	
int32u channelMask	Bits set as 1 indicate that this particular channel should be scanned. Bits set to 0 indicate that this particular channel should not be scanned. For example, a channelMask value of 0x00000001 would indicate that only channel 0 should be scanned. Valid channels range from 11 to 26 inclusive. This translates to a channel mask value of 0x07FFF800.
int8s radioTxPower	A power setting, in dBm.
<p>Response Parameters: None</p>	

Name: scanAndJoinNetwork	ID: 0x50
<p>Description: Scan and join a network. This performs the following actions: 1. Does an active scan to find a network that uses our stack profile and currently allows new nodes to join. 2. Joins the chosen network. If any errors occur the status code is passed to the <code>scanErrorHandler</code> callback and no network is joined. Success is indicated when the <code>stackStatusHandler</code> callback is invoked with the <code>EMBER_NETWORK_UP</code> status value.</p>	
<p>Command Parameters:</p>	
EmberNodeType nodeType	Specification of the role that this node will have in the network. This role must not be <code>EMBER_COORDINATOR</code> . To be a coordinator, use the <code>scanAndFormNetwork</code> command.
int32u channelMask	Bits set as 1 indicate that this particular channel should be scanned. Bits set to 0 indicate that this particular channel should not be scanned. For example, a channelMask value of 0x00000001 would indicate that only channel 0 should be scanned. Valid channels range from 11 to 26 inclusive. This translates to a channel mask value of 0x07FFF800.
int8s radioTxPower	A power setting, in dBm.
boolean joinSecurely	If true, the node uses the current key to secure messages during the joining process. The proper value for secured networks depends upon their configuration. Some networks use unsecured joining and distribute the key from the coordinator. Other networks require secure joining and accept only nodes that know the correct key. This value has no effect if the security level is 0.
<p>Response Parameters: None</p>	

EM260

Name: scanErrorHandler	ID: 0x51
Description: This callback is invoked if an error occurs while attempting to <code>scanAndFormNetwork</code> or <code>scanAndJoinNetwork</code> .	
This frame is a response to the <code>callback</code> command.	
Response Parameters:	
EmberStatus status	An EmberStatus value indicating the reason for the <code>scanAndFormNetwork</code> or <code>scanAndJoinNetwork</code> failure.

Name: leaveNetwork	ID: 0x20
Description: Causes the stack to leave the current network. This generates a <code>stackStatusHandler</code> callback to indicate that the network is down. The radio will not be used until after sending a <code>formNetwork</code> or <code>joinNetwork</code> command.	
Command Parameters: None	
Response Parameters:	
EmberStatus status	An EmberStatus value indicating success or the reason for failure.

Name: mobileNodeHasMoved	ID: 0x21
Description: Informs the stack that contact with the network has been lost. Only devices that are joined to a network with a node type of <code>EMBER_MOBILE_END_DEVICE</code> may call this function. This generates a <code>stackStatusHandler</code> callback to indicate that the network is down. The stack will try to re-establish contact with the network. A second <code>stackStatusHandler</code> callback indicates either the success or the failure of the attempt.	
Command Parameters: None	
Response Parameters:	
EmberStatus status	An EmberStatus value indicating success or the reason for failure.

Name: permitJoining	ID: 0x22
Description: Tells the stack to allow other nodes to join the network with this node as their parent. Joining is initially disabled by default.	
Command Parameters:	
int8u duration	A value of <code>0x00</code> disables joining. A value of <code>0xFF</code> enables joining. Any other value enables joining for that number of seconds.
Response Parameters:	
EmberStatus status	An EmberStatus value indicating success or the reason for failure.

Name: childJoinHandler	ID: 0x23
Description: Indicates that a child has joined or left.	
This frame is a response to the <code>callback</code> command.	
Response Parameters:	
int8u index	The index of the child of interest.
boolean joining	True if the child is joining. False the child is leaving.
EmberNodeid childId	The node ID of the child.
EmberEUI64 childEui64	The EUI64 of the child.
EmberNodeType childType	The node type of the child.

Name: trustCenterJoinHandler	ID: 0x24
Description: The EM260 used the trust center behavior policy to decide whether to allow a new node to join the network. The Host cannot change the current decision, but it can change the policy for future decisions using the <code>setPolicy</code> command.	
This frame is a response to the <code>callback</code> command.	
Response Parameters:	
EmberEUI64 newNode	The EUI64 of the node that wished to join.
boolean securedJoin	True if the node was joining securely using the network security key.
EmberJoinDecision policyDecision	An EmberJoinDecision reflecting the decision made.

Name: sendDiscoveryInformationToParent	ID: 0x25
Description: Initiates the upload of discovery information to the parent of this node. Only devices that are joined to a network with a node type of <code>EMBER_SLEEPY_END_DEVICE</code> may call this function. The parent stores the information in its discovery cache. The information is sent using ZDO messages with cluster IDs <code>NODE_DESCRIPTOR_RESPONSE</code> , <code>POWER_DESCRIPTOR_RESPONSE</code> and <code>SIMPLE_DESCRIPTOR_RESPONSE</code> .	
Command Parameters: None	
Response Parameters:	
EmberStatus status	An EmberStatus value indicating success or the reason for failure.

Name: getEui64	ID: 0x26
Description: Returns the EUI64 ID of the local node.	
Command Parameters: None	
Response Parameters:	
EmberEUI64 eui64	The 64-bit ID.

EM260

Name: getNodeId	ID: 0x27
Description: Returns the 16-bit node ID of the local node.	
Command Parameters: None	
Response Parameters:	
EmberNodeId nodeId	The 16-bit ID.

Name: getNetworkParameters	ID: 0x28
Description: Returns the current network parameters.	
Command Parameters: None	
Response Parameters:	
EmberStatus status	An EmberStatus value indicating success or the reason for failure.
EmberNodeType nodeType	An EmberNodeType value indicating the current node type.
EmberNetworkParameters parameters	The current network parameters.

Name: getParentChildParameters	ID: 0x29
Description: Returns information about the children of the local node and the parent of the local node.	
Command Parameters: None	
Response Parameters:	
int8u childCount	The number of children the node currently has.
EmberEUI64 parentEui64	The parent's EUI64. The value is undefined for nodes without parents (coordinators and nodes that are not joined to a network).
EmberNodeId parentNodeId	The parent's node ID. The value is undefined for nodes without parents (coordinators and nodes that are not joined to a network).

Name: getChildData	ID: 0x4A
Description: Returns information about a child of the local node.	
Command Parameters:	
int8u index	The index of the child of interest in the child table. Possible indexes range from zero to EMBER_CHILD_TABLE_SIZE.
Response Parameters:	
EmberStatus status	EMBER_SUCCESS if there is a child at <code>index</code> . EMBER_NOT_JOINED if there is no child at <code>index</code> .
EmberNodeId childId	The node ID of the child.
EmberEUI64 childEui64	The EUI64 of the child.
EmberNodeType childType	The EmberNodeType value for the child.

6.3.7 Binding Frames

Name: clearBindingTable	ID: 0x2A
Description: Deletes all binding table entries.	
Command Parameters: None	
Response Parameters:	
EmberStatus status	An EmberStatus value indicating success or the reason for failure.

Name: setBinding	ID: 0x2B
Description: Sets an entry in the binding table.	
Command Parameters:	
int8u index	The index of a binding table entry.
EmberBindingTableEntry value	The contents of the binding entry.
Response Parameters:	
EmberStatus status	An EmberStatus value indicating success or the reason for failure.

Name: getBinding	ID: 0x2C
Description: Gets an entry from the binding table.	
Command Parameters:	
int8u index	The index of a binding table entry.
Response Parameters:	
EmberStatus status	An EmberStatus value indicating success or the reason for failure.
EmberBindingTableEntry value	The contents of the binding entry.

Name: deleteBinding	ID: 0x2D
Description: Deletes a binding table entry.	
Command Parameters:	
int8u index	The index of a binding table entry.
Response Parameters:	
EmberStatus status	An EmberStatus value indicating success or the reason for failure.

EM260

Name: bindingsActive	ID: 0x2E
Description: Indicates whether a binding table entry is active—that is, whether a connection to it is open or any messages are en route from it. Note that this command does not indicate whether a binding is clear. To determine whether a binding is clear, check whether the type field of the EmberBindingTableEntry has the value EMBER_UNUSED_BINDING.	
Command Parameters:	
int8u index	The index of a binding table entry.
Response Parameters:	
boolean active	True if the binding table entry is active. False if the binding table entry is not active.

Name: getBindingDestinationNodeId	ID: 0x2F
Description: Returns the node ID for the binding's destination, if the ID is known. If a message is sent using the binding and the destination's ID is not known, the stack will discover the ID by broadcasting a ZDO address request. The application can avoid the need for this discovery by using <code>setBindingDestinationNodeId</code> when it knows the correct ID via some other means. The destination's node ID is forgotten when the binding is changed, when the local node reboots or, much more rarely, when the destination node changes its ID in response to an ID conflict.	
Command Parameters:	
int8u index	The index of a binding table entry.
Response Parameters:	
EmberNodeId nodeId	The short ID of the destination node or EMBER_NULL_NODE_ID if no destination is known.

Name: setBindingDestinationNodeId	ID: 0x30
Description: Set the node ID for the binding's destination. See <code>getBindingDestinationNodeId</code> for a description.	
Command Parameters:	
int8u index	The index of a binding table entry.
EmberNodeId nodeId	The short ID of the destination node.
Response Parameters: None	

Name: remoteSetBindingHandler	ID: 0x31
Description: The EM260 used the external binding modification policy to decide how to handle a remote set binding request. The Host cannot change the current decision, but it can change the policy for future decisions using the <code>setPolicy</code> command.	
This frame is a response to the <code>callback</code> command.	
Response Parameters:	
EmberBindingTableEntry entry	The requested binding.
int8u index	The index at which the binding was added.
EmberStatus policyDecision	EMBER_SUCCESS if the binding was added to the table and any other status if not.

Name: remoteDeleteBindingHandler	ID: 0x32
Description: The EM260 used the external binding modification policy to decide how to handle a remote delete binding request. The Host cannot change the current decision, but it can change the policy for future decisions using the <code>setPolicy</code> command.	
This frame is a response to the <code>callback</code> command.	
Response Parameters:	
int8u index	The index of the binding whose deletion was requested.
EmberStatus policyDecision	EMBER_SUCCESS if the binding was removed from the table and any other status if not.

6.3.8 Messaging Frames

Name: maximumPayloadLength	ID: 0x33
Command Parameters: None	
Response Parameters:	
int8u apsLength	The maximum APS payload length.
int8u transportLength	The maximum transport payload length.

Name: sendUnicast	ID: 0x34
Description: Sends a unicast message as per the ZigBee specification. The message will arrive at its destination only if there is a known route to the destination node. Setting the <code>ENABLE_ROUTE_DISCOVERY</code> option will cause a route to be discovered if none is known. Setting the <code>FORCE_ROUTE_DISCOVERY</code> option will force route discovery. Routes to end-device children of the local node are always known. Setting the <code>APS_RETRY</code> option will cause the message to be retransmitted until either a matching acknowledgement is received or three transmissions have been made. The ZigBee APS retry mechanism does not use sequence numbers. If multiple messages are sent to the same destination at the same time any acknowledgement from that node will stop transmission of all outstanding messages. Note: Using the <code>FORCE_ROUTE_DISCOVERY</code> option will cause the first transmission to be consumed by a route request as part of discovery, so the application payload of this packet will not reach its destination on the first attempt. If you want the packet to reach its destination, the <code>APS_RETRY</code> option must be set so that another attempt is made to transmit the message with its application payload after the route has been constructed.	
Command Parameters:	
EmberNodeid destination	The node ID to which the message will be sent.
EmberApsFrame apsFrame	The APS frame for the message.
int8u messageTag	A value chosen by the Host. This value is used in the <code>emberUnicastSent</code> response to refer to this message.
int8u messageLength	The length of the <code>messageContents</code> parameter in bytes.
int8u[] messageContents	The unicast message.
Response Parameters:	
EmberStatus status	An EmberStatus value indicating success or the reason for failure.

EM260

Name: unicastSent	ID: 0x35
Description: A callback indicating the stack has completed sending a non-transport unicast message. Except for the status value, the parameters are identical to those of the <code>sendUnicast</code> command used to send the message.	
This frame is a response to the <code>callback</code> command.	
Response Parameters:	
EmberNodeld destination	The node ID to which the message was be sent.
EmberApsFrame apsFrame	The APS frame for the message.
int8u messageTag	The value supplied by the Host in the <code>emberSendUnicast</code> command.
EmberStatus status	An EmberStatus value indicating success or the reason for failure.
int8u messageLength	The length of the <code>messageContents</code> parameter in bytes.
int8u[] messageContents	The unicast message supplied by the Host. The message contents are only included here if the decision for the <code>messageContentsInCallback</code> policy is <code>messageTagAndContentsInCallback</code> .

Name: sendBroadcast	ID: 0x36
Description: Sends a broadcast message as per the ZigBee specification.	
Command Parameters:	
EmberApsFrame apsFrame	The APS frame for the message.
int8u radius	The message will be delivered to all nodes within <code>radius</code> hops of the sender. A radius of zero is converted to <code>EMBER_MAX_HOPS</code> .
int8u messageTag	Reserved for future use. This value is ignored by the EM260.
int8u messageLength	The length of the <code>messageContents</code> parameter in bytes.
int8u[] messageContents	The broadcast message.
Response Parameters:	
EmberStatus status	An EmberStatus value indicating success or the reason for failure.

Name: sendDatagram	ID: 0x37
Description: Sends a datagram to the node and endpoint specified in a binding table entry. The status of the delivery will be reported by a <code>messageSent</code> callback.	
Command Parameters:	
int8u bindingTableIndex	The index of the binding table entry.
int8u clusterId	The cluster ID to use.
int8u messageTag	A value chosen by the Host. This value is used in the <code>emberCancelMessage</code> command and the <code>emberMessageSent</code> response to refer to this message.
int8u messageLength	The length of the <code>messageContents</code> parameter in bytes.
int8u[] messageContents	The datagram message.
Response Parameters:	
EmberStatus status	<p>An EmberStatus value. For any result other than <code>EMBER_SUCCESS</code>, the message will not be sent.</p> <ul style="list-style-type: none"> ■ <code>EMBER_SUCCESS</code>: The message has been submitted for transmission. ■ <code>EMBER_INVALID_BINDING_INDEX</code>: The <code>bindingTableIndex</code> refers to a non-unicast binding. <code>EMBER_NETWORK_DOWN</code>: The node is not part of a network. ■ <code>EMBER_MESSAGE_TOO_LONG</code>: The message is too large to fit in a MAC layer frame. ■ <code>EMBER_MAX_MESSAGE_LIMIT_REACHED</code>: The <code>EMBER_TRANSPORT_PACKET_COUNT</code> limit has been reached.

EM260

Name: sendMulticast	ID: 0x38
Description: Sends a multicast message to all endpoints that share a specific multicast ID and are within a specified number of hops of the sender.	
Command Parameters:	
int8u bindingTableIndex	The index of the binding table entry specifying the multicast group.
int8u clusterId	The cluster ID to use.
int8u messageTag	Reserved for future use. This value is ignored by the EM260.
int8u hops	The message will be delivered to all nodes within this number of hops of the sender. A value of zero is converted to EMBER_MAX_HOPS.
int8u messageLength	The length of the <code>messageContents</code> parameter in bytes.
int8u[] messageContents	The multicast message.
Response Parameters:	
EmberStatus status	An EmberStatus value. For any result other than EMBER_SUCCESS, the message will not be sent. <ul style="list-style-type: none">■ EMBER_SUCCESS: The message has been submitted for transmission.■ EMBER_INVALID_BINDING_INDEX: The bindingTableIndex refers to a non-multicast binding.■ EMBER_NETWORK_DOWN: The node is not part of a network.■ EMBER_MESSAGE_TOO_LONG: The message is too large to fit in a MAC layer frame.■ EMBER_NO_BUFFERS: The free packet buffer pool is empty.■ EMBER_NETWORK_BUSY: Insufficient resources available in Network or MAC layers to send message.

Name: sendReply	ID: 0x39
Description: Sends a reply to a received datagram message. The <code>incomingMessageHandler</code> callback for the datagram being replied to supplies the values for all the parameters except the reply itself.	
Command Parameters:	
EmberNodeId sender	Value supplied by incoming datagram.
EmberApsFrame apsFrame	Value supplied by incoming datagram.
int8u datagramReplyTag	Value supplied by incoming datagram.
int8u messageLength	The length of the <code>messageContents</code> parameter in bytes.
int8u[] messageContents	The reply message.
Response Parameters:	
EmberStatus status	An EmberStatus value indicating success or the reason for failure.

Name: openConnection	ID: 0x3A
Description: Opens a sequenced connection to a node.	
Command Parameters:	
int8u bindingTableIndex	The index of the binding table entry to which a connection will be opened.
Response Parameters:	
EmberStatus status	An EmberStatus value indicating success or the reason for failure.

Name: connectionStatus	ID: 0x3B
Description: Returns the connection status of a binding table entry.	
Command Parameters:	
int8u bindingTableIndex	The index of the binding table entry whose status is being queried.
Response Parameters:	
EmberStatus status	An EmberStatus value: <ul style="list-style-type: none">■ EMBER_CONNECTION_CLOSED: The connection is closed.■ EMBER_CONNECTION_NOT_YET_OPEN: The connection is in the process of being established.■ EMBER_CONNECTION_OPEN: The connection is currently established.■ EMBER_CONNECTION_CLOSING: The connection is in the process of being closed.

Name: connectionStatusHandler	ID: 0x3C
Description: A callback indicating the status of a connection has changed.	
This frame is a response to the <code>callback</code> command.	
Response Parameters:	
int8u bindingTableIndex	The index of the binding table entry whose connection status has changed.
EmberStatus status	An EmberStatus value: <ul style="list-style-type: none">■ EMBER_CONNECTION_OPEN : A sequenced connection has successfully been established for the binding. It may have been initiated locally or remotely.■ EMBER_CONNECTION_CLOSING: The sequenced connection for the binding is being closed gracefully. The close may have been initiated locally or remotely. As soon as the disposition of all in-flight messages has been resolved the connection will be completely closed (and the EMBER_CONNECTION_CLOSED status will be reported).■ EMBER_CONNECTION_CLOSED: The sequenced connection has been successfully closed. The disposition of every message sent over the connection has already been reported (via the various callbacks). There will be no further message related callbacks.■ EMBER_CONNECTION_FAILED: The sequenced connection has been closed unexpectedly. If there were messages in-flight their disposition will never be known or reported via callbacks. This error may be reported during the opening of a connection, while a connection is established or during the closing of a connection.■ EMBER_INCOMING_SEQUENCED_MESSAGES_LOST: One or more sequenced messages have not been received on the connection and it has been determined they will never be received.

Name: sendSequenced	ID: 0x3D
Description: Sends a sequenced message over the connection associated with a specified binding table entry.	
Command Parameters:	
int8u bindingTableIndex	The index of the binding table entry specifying the message destination.
int8u clusterId	The cluster ID to use.
int8u messageTag	A value chosen by the Host. This value is used in the <code>emberCancelMessage</code> command and the <code>emberMessageSent</code> response to refer to this message.
int8u messageLength	The length of the <code>messageContents</code> parameter in bytes.
int8u[] messageContents	The sequenced message.
Response Parameters:	
EmberStatus status	An EmberStatus value. For any result other than EMBER_SUCCESS, the message will not be sent. <ul style="list-style-type: none"> ■ EMBER_SUCCESS: The message has been submitted for transmission. ■ EMBER_CONNECTION_CLOSED: The connection associated with bindingTableIndex is either closed or in the process of closing. ■ EMBER_INVALID_BINDING_INDEX: The bindingTableIndex refers to a non-unicast binding. ■ EMBER_NETWORK_DOWN: The node is not part of a network. ■ EMBER_MESSAGE_TOO_LONG: The message is too large to fit in a MAC layer frame. ■ EMBER_MAX_MESSAGE_LIMIT_REACHED: Either the EMBER_TRANSPORT_PACKET_COUNT limit has been reached or the transmit window is full (i.e. there are already 8 sequenced messages in flight on the connection).

Name: closeConnection	ID: 0x3E
Description: Closes a connection. Any sequenced messages previously sent on the connection will be delivered before the connection is closed. Similarly, all messages sent by the remote node before the connection close is initiated will be received before the connection closes locally.	
Command Parameters:	
int8u bindingTableIndex	The index of the binding table entry whose connection is to be closed.
Response Parameters:	
EmberStatus status	An EmberStatus value indicating success or the reason for failure.

EM260

Name: messageSent	ID: 0x3F
Description: A callback indicating the stack has completed sending a datagram or sequenced message.	
This frame is a response to the <code>callback</code> command.	
Response Parameters:	
int8u bindingTableIndex	The index of the binding table entry to which the message was sent.
int8u clusterId	The cluster ID that was used.
int8u messageTag	The value supplied by the Host in the <code>emberSendDatagram</code> OR <code>emberSendSequenced</code> command.
EmberStatus status	An EmberStatus value of <code>EMBER_SUCCESS</code> if an ACK was received from the destination or <code>EMBER_DELIVERY_FAILED</code> if no ACK was received.
int8u messageLength	The length of the <code>messageContents</code> parameter in bytes.
int8u[] messageContents	The unicast message supplied by the Host. The message contents are only included here if the decision for the <code>messageContentsInCallback</code> policy is <code>messageTagAndContentsInCallback</code> .

Name: cancelMessage	ID: 0x40
Description: Cancels an outgoing message.	
Command Parameters:	
int8u messageTag	The value supplied by the Host in the <code>emberSendDatagram</code> OR <code>emberSendSequenced</code> command.
Response Parameters:	
EmberStatus status	Always returns <code>EMBER_SUCCESS</code> .

Name: createAggregationRoutes	ID: 0x41
Description: Sends a route request that creates routes from every node in the network back to this node. This function should be called by the application if it wishes to aggregate data from many nodes. The data sources will not have to discover routes individually. Additionally, incoming data will set up temporary reverse routes that allow acknowledgement messages to return without a route discovery. The temporary routes expire and become reusable after a single use, or 10-20 seconds.	
Command Parameters: None	
Response Parameters:	
EmberStatus status	<code>EMBER_SUCCESS</code> if the route request was successfully submitted to the transmit queue, and <code>EMBER_ERR_FATAL</code> otherwise.

Name: pollForData	ID: 0x42
Description: Periodically request any pending data from our parent. Setting <code>interval</code> to 0 or <code>units</code> to <code>EMBER_EVENT_INACTIVE</code> will generate a single poll.	
Command Parameters:	
int16u interval	The time between polls. Note that the timer clock is free running and is not synchronized with this command. This means that the time will be between <code>interval</code> and <code>(interval - 1)</code> . The maximum interval is 32767.
EmberEventUnits units	The units for <code>interval</code> .
int8u failureLimit	The number of poll failures that will be tolerated before a <code>pollCompleteHandler</code> callback is generated. A value of zero will result in a callback for every poll. Any status value apart from <code>EMBER_SUCCESS</code> and <code>EMBER_MAC_NO_DATA</code> is counted as a failure.
Response Parameters:	
EmberStatus status	The result of sending the first poll.

Name: pollCompleteHandler	ID: 0x43
Description: Indicates the result of a data poll to the parent of the local node.	
This frame is a response to the <code>callback</code> command.	
Response Parameters:	
EmberStatus status	An EmberStatus value: <ul style="list-style-type: none"> ■ <code>EMBER_SUCCESS</code>: Data was received in response to the poll. ■ <code>EMBER_MAC_NO_DATA</code>: No data was pending. ■ <code>EMBER_DELIVERY_FAILED</code>: The poll message could not be sent. ■ <code>EMBER_MAC_NO_ACK_RECEIVED</code>: The poll message was sent but not acknowledged by the parent.

Name: pollHandler	ID: 0x44
Description: Indicates that the local node received a data poll from a child.	
This frame is a response to the <code>callback</code> command.	
Response Parameters:	
EmberNodeId childId	The node ID of the child that is requesting data.

EM260

Name: incomingMessageHandler	ID: 0x45
Description: A callback indicating a message has been received.	
This frame is a response to the <code>callback</code> command.	
Response Parameters:	
EmberIncomingMessageType type	The type of the incoming message. One of the following: <ul style="list-style-type: none">■ EMBER_INCOMING_DATAGRAM,■ EMBER_INCOMING_DATAGRAM_REPLY,■ EMBER_INCOMING_SEQUENCED,■ EMBER_INCOMING_MULTICAST,■ EMBER_INCOMING_SHARED_MULTICAST,■ EMBER_INCOMING_MULTICAST_LOOPBACK,■ EMBER_INCOMING_UNICAST,■ EMBER_INCOMING_BROADCAST
EmberApsFrame apsFrame	The APS frame from the incoming message.
int8u lastHopLqi	The link quality from the node that last relayed the message.
int8s lastHopRssi	The energy level (in units of dBm) observed during the reception.
EmberNodeId sender	The sender of the message.
int8u bindingIndex	The index of a binding that matches the message or 0xFF if there is no matching binding.
int8u datagramReplyTag	If the incoming message is a datagram and the Host wishes to send a reply, this value must be supplied to the <code>emberSendReply</code> command.
int8u messageLength	The length of the <code>messageContents</code> parameter in bytes.
int8u[] messageContents	The incoming message.

6.3.9 Alphabetical List of Frames

Frame Name	ID
addEndpoint	0x02
bindingsActive	0x2E
callback	0x06
cancelMessage	0x40
childJoinHandler	0x23
clearBindingTable	0x2A
closeConnection	0x3E
connectionStatus	0x3B
connectionStatusHandler	0x3C
createAggregationRoutes	0x41
debugHandler	0x13
debugWrite	0x12
deleteBinding	0x2D
energyScanResultHandler	0x48
formNetwork	0x1E
getBinding	0x2C
getBindingDestinationNodeId	0x2F
getChildData	0x4A
getConfigurationValue	0x52
getEui64	0x26
getMfgToken	0x0B
getMillisecondTime	0x0D
getNetworkParameters	0x28
getNodeId	0x27
getParentChildParameters	0x29
getPolicy	0x56
getRam	0x47
getRandomNumber	0x49
getTimer	0x4E
getToken	0x0A
incomingMessageHandler	0x45
invalidCommand	0x58
joinNetwork	0x1F
leaveNetwork	0x20

Frame Name	ID
maximumPayloadLength	0x33
messageSent	0x3F
mobileNodeHasMoved	0x21
networkFoundHandler	0x1B
networkInit	0x17
networkState	0x18
noCallbacks	0x07
nop	0x05
openConnection	0x3A
permitJoining	0x22
pollCompleteHandler	0x43
pollForData	0x42
pollHandler	0x44
remoteDeleteBindingHandler	0x32
remoteSetBindingHandler	0x31
reset	0x08
scanAndFormNetwork	0x4F
scanAndJoinNetwork	0x50
scanCompleteHandler	0x1C
scanErrorHandler	0x51
sendBroadcast	0x36
sendDatagram	0x37
sendDiscoveryInformationToParent	0x25
sendMulticast	0x38
sendReply	0x39
sendSequenced	0x3D
sendUnicast	0x34
serialRead	0x11
serialWrite	0x10
setBinding	0x2B
setBindingDestinationNodeId	0x30
setConfigurationValue	0x53
setEncryptionKey	0x14
setManufacturerCode	0x15
setPolicy	0x55

Frame Name	ID
setPowerDescriptor	0x16
setRam	0x46
setTimer	0x0E
setToken	0x09
stackStatusHandler	0x19
startScan	0x1A
stopScan	0x1D
timerHandler	0x0F
trustCenterJoinHandler	0x24
unicastSent	0x35
version	0x00

6.4 Sample Transactions

The following sections illustrate the following sample transactions:

- Joining
- Binding
- Sending
- Receiving

6.4.1 Joining

```
1) frame control      = 0x00 (command frame, don't sleep)
   joinNetwork command = 0x1F
   nodeType           = 0x02 (EMBER_ROUTER)
   panId              = 0x1234
   radioTxPower       = 0xFF (-1)
   radioChannel       = 0x0B (11)
   useKey             = 0x00 (FALSE)
```

```
HOST -> EM260: | 00 | 1F | 02 | 34 | 12 | FF | 0B | 00 |
```

```
frame control      = 0x80 (response frame, no overflow, not truncated)
joinNetwork response = 0x1F
status             = 0x00 (EMBER_SUCCESS)
```

```
EM260 -> HOST: | 80 | 1F | 00 |
```

2) Host waits for callback signal while EM260 tries to join the network.

```
3) frame control      = 0x00 (command frame, don't sleep)
   callback command   = 0x06
```

HOST -> EM260: | 00 | 06 |

frame control = 0x80 (response frame, no overflow, not truncated)
stackStatusHandler response = 0x19
status = 0x90 (EMBER_NETWORK_UP)

EM260 -> HOST: | 80 | 19 | 90 |

6.4.2 Binding

1) frame control = 0x00 (command frame, don't sleep)
setBinding command = 0x2B
index = 0x00
type = 0x01 (EMBER_UNICAST_BINDING)
local = 0x11
remote = 0x12
clusterId = 0x55
identifier = 0x1122334455667788

HOST -> EM260: | 00 | 2B | 00 | 01 | 11 | 12 | 55 | 88 | 77 | 66 | 55
| 44 | 33 | 22 | 11 |

frame control = 0x80 (response frame, no overflow, not truncated)
setBinding response = 0x2B
status = 0x00 (EMBER_SUCCESS)

EM260 -> HOST: | 80 | 2B | 00 |

6.4.3 Sending

1) frame control = 0x00 (command frame, don't sleep)
sendDatagram command = 0x37
bindingTableIndex = 0x00
clusterId = 0x55
messageTag = 0x01
messageLength = 0x03
messageContents = 0xE1, 0xE2, 0xE3

HOST -> EM260: | 00 | 37 | 00 | 55 | 01 | 03 | E1 | E2 | E3 |

frame control = 0x80 (response frame, no overflow, not truncated)
sendDatagram response = 0x37
status = 0x00 (EMBER_SUCCESS)

EM260 -> HOST: | 80 | 37 | 00 |

2) Host waits for callback signal while EM260 tries to send the message.

3) frame control = 0x00 (command frame, don't sleep)
callback command = 0x06

HOST -> EM260: | 00 | 06 |

frame control = 0x80 (response frame, no overflow, not truncated)
messageSent response = 0x3F
bindingTableIndex = 0x00
clusterId = 0x55
messageTag = 0x01
status = 0x00 (EMBER_SUCCESS)

EM260 -> HOST: | 80 | 3F | 00 | 55 | 01 | 00 |

6.4.4 Receiving

- 1) Host waits for callback signal after a message is received by the EM260.
- 2) frame control = 0x00 (command frame, don't sleep)
callback command = 0x06

```
HOST -> EM260: | 00 | 06 |
```

```
frame control           = 0x80 (response frame, no overflow, not truncated)
incomingMessageHandler response = 0x45
type                   = 0x00 (EMBER_INCOMING_DATAGRAM)
profileId              = 0xABCD
clusterId              = 0x55
sourceEndpoint         = 0x11
destinationEndpoint    = 0x12
options                = 0x00
lastHopLqi             = 0xF0
lastHopRssi            = 0xC4 (-60)
sender                 = 0x0001
bindingIndex           = 0xFF
datagramReplyTag       = 0x01
messageLength          = 0x03
messageContents        = 0xE1, 0xE2, 0xE3
```

```
EM260 -> HOST: | 80 | 45 | 00 | CD | AB | 55 | 11 | 12 | 00 | F0 | C4
                | 01 | 00 | FF | 01 | 03 | E1 | E2 | E3 |
```

7 SIF Module Programming and Debug Interface

SIF is a synchronous serial interface developed by Cambridge Consultants Ltd. It is the primary programming and debug interface of the EM260. Therefore, any design implementing the EM260 should make the SIF signals readily available. The SIF module allows external devices to read and write memory-mapped registers in real-time without changing the functionality or timing of the XAP2b core. See the *EM260 Reference Design* for details regarding the implementation of the SIF interface.

The SIF interface provides the following:

- IC production test (especially analog)
- PCB production test
- Firmware download
- Product control and characterization

The pins are:

- nSIF_LOAD
- SIF_CLK
- SIF_MOSI
- SIF_MISO

The maximum serial shift speed for the SIF interface is 48MHz. SIF interface accesses can be initiated even when the chip is in idle, deep sleep, or power down modes. An edge on nSIF_LOAD wakes the chip to allow SIF cycles.

8 Typical Application

Figure 12 illustrates the typical application circuit for the EM260. This figure does not contain all decoupling capacitance required by the EM260. The Balun provides the impedance transformation from the antenna to the EM260 for both TX and RX modes. The harmonic filter provides additional suppression of the second harmonic, which increases the margin over the FCC limit. The 24MHz crystal with loading capacitors is required and provides the high frequency source for the EM260. The RC debounce filter (R4 and C7) is suggested to improve the noise immunity of the nRESET logic (Pin 11).

The SIF (nSIF_LOAD, SIF_MOSI, SIF_MISO, and SIF_CLK) and Packet Trace Signals (PTI_EN and PTI_TXD) should be brought out test points or, if space permits to a 10-pin, dual row, 0.05-inch pitch header footprint. With a header populated, a direct connection to the InSight Adapter is possible which enhances the debug capability of the EM260. For more information, refer to the *EM260 Reference Design*.

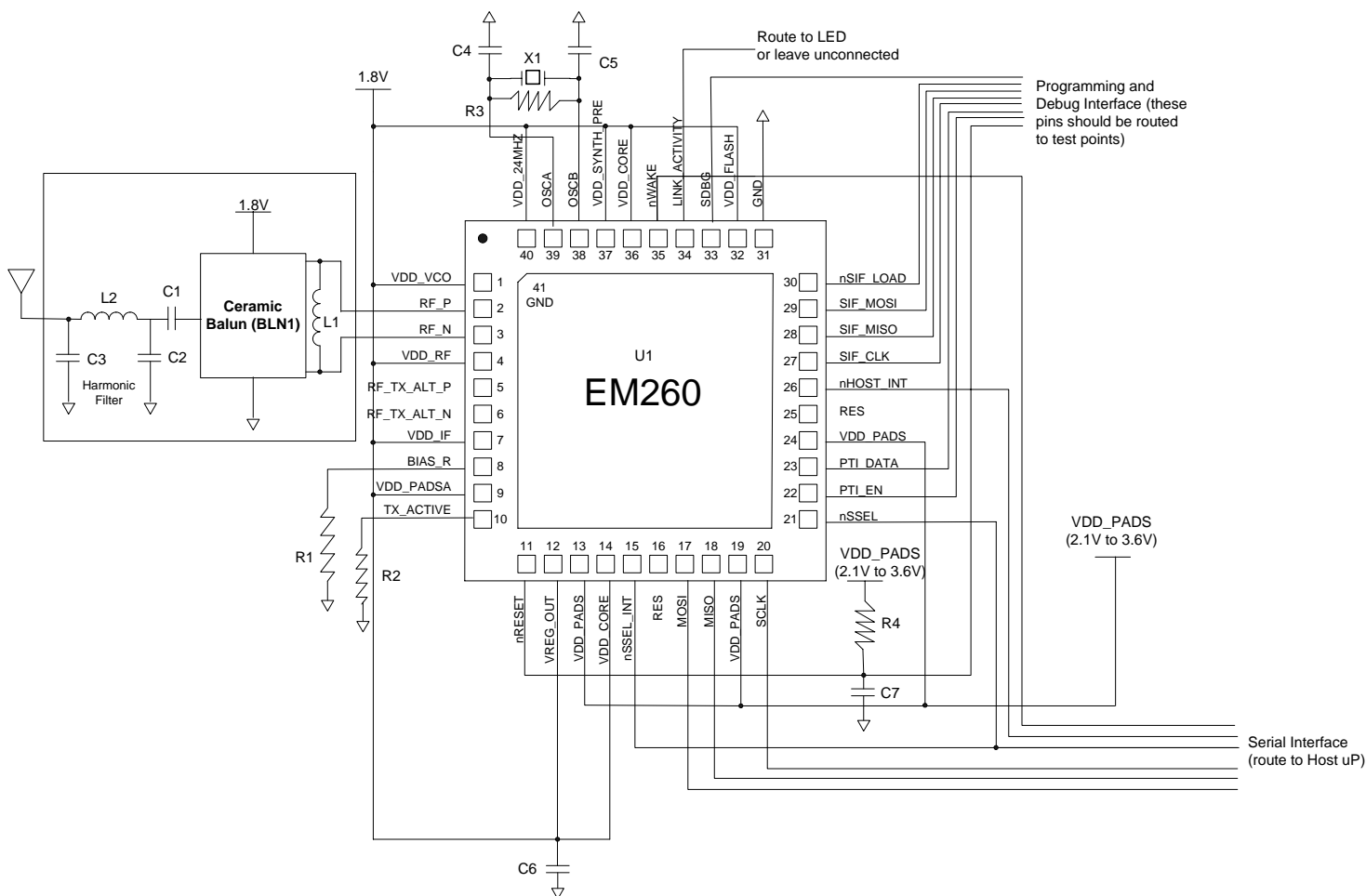

Figure 12. Typical Application Circuit

Table 22 contains the Bill of Materials for the application circuit shown in Figure 12.

Table 22. Bill of Materials

Item	Quantity	Reference	Description	Manufacturer/Part No.
1	1	C2	CAPACITOR, 5PF, 50V, NPO, 0402	<not specified>
2	2	C1,C3	CAPACITOR, 0.5PF, 50V, NPO, 0402	<not specified>
3	4	C4,C5	CAPACITOR, 27PF, 50V, NPO, 0402	<not specified>
4	1	C6	CAPACITOR, 10UF, 10V, TANTALUM, 3216 (SIZE A)	<not specified>
5	1	C7	CAPACITOR, 10PF, 5V, NPO, 0402	<not specified>
6	1	L1	INDUCTOR, 2.7NH, +/- 5%, 0603, MULTILAYER	MURATA LOG18HN2N7
7	2	L2	INDUCTOR, 3.3NH, +/- 5%, 0603, MULTILAYER	MURATA LOG18HN3N3
8	1	R1	RESISTOR, 169 KOHM, 1%, 0402	<not specified>
9	1	R2	RESISTOR, 100 KOHM, 5% 0402	<not specified>
10	1	R3	RESISTOR, 3.3 KOHM, 5% 0402	<not specified>
11	1	R4	RESISTOR, 10 KOHM, 5%, 0402	<not specified>
12	1	U1	EM260 SINGLE-CHIP ZIGBEE/802.15.4 SOLUTION	EMBER EM260
13	1	X1	CRYSTAL, 24.000MHZ, +/- 10PPM TOLERANCE, +/- 25PPM STABILITY, 18PF, - 40 TO + 85C	ILSI ILCX08-JG5F18-24.000MHZ
14	1	BLN1	BALUN, CERAMIC	TDK HHM1521

9 Mechanical Details

The EM260 package is a plastic 40-pin QFN that is 6mm x 6mm x 0.9mm. A large ground pad in the bottom center of the package forms a 41st pin. A number of thermal vias should connect the EM260 decal center to a PCB ground plane. For more information, refer to the *EM260 Reference Design*.

Figure 13 illustrates the package drawing.

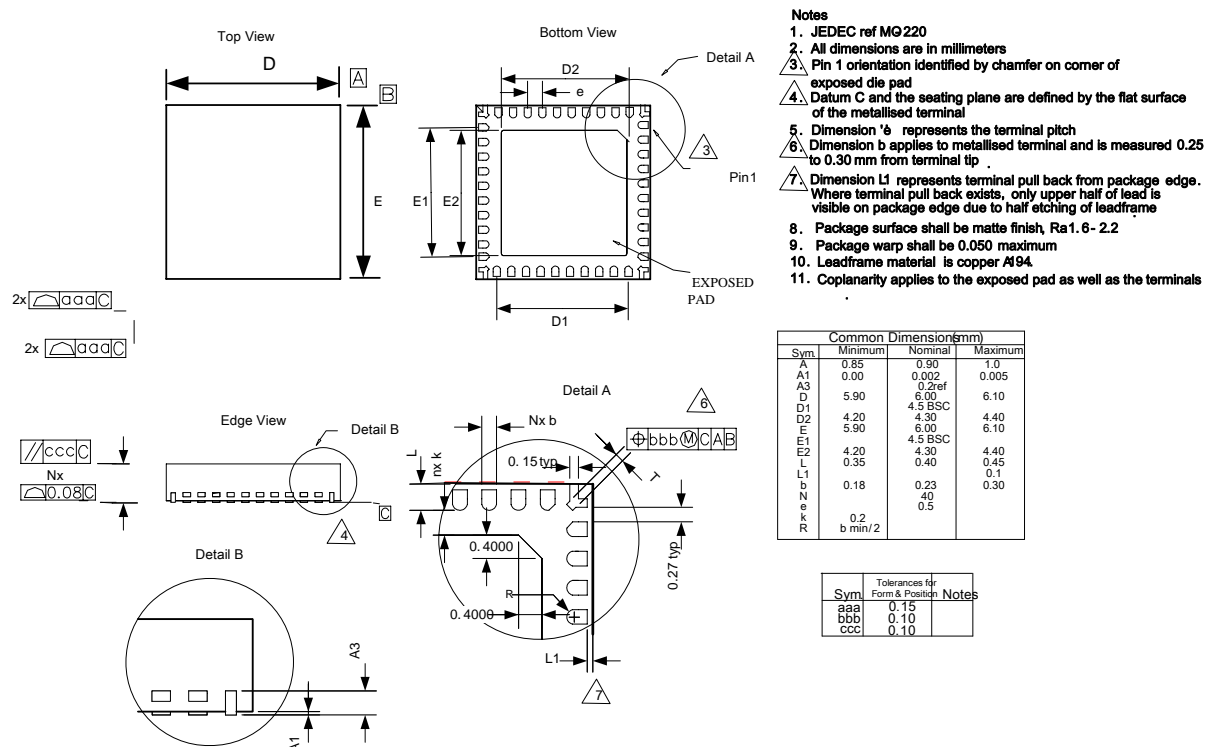

Figure 13. Package Drawing

EM260

10 Ordering Information

Use the following part numbers to order the EM260:

- EM260-RTR Reel, RoHS
- EM260-RTY Tray, RoHS

To order parts, contact Ember at +1-617-951-0200, or send your inquiry by email to sales@ember.com. Details about our international distributors can be found on our Web site: www.ember.com.

11 Abbreviations and Acronyms

Acronym/Abbreviation	Meaning
ACR	Adjacent Channel Rejection
AES	Advanced Encryption Standard
CBC-MAC	Cipher Block Chaining—Message Authentication Code
CCA	Clear Channel Assessment
CCM	Counter with CBC-MAC Mode for AES encryption
CCM*	Improved Counter with CBC-MAC Mode for AES encryption
CSMA	Carrier Sense Multiple Access
CTR	Counter Mode
EEPROM	Electrically Erasable Programmable Read Only Memory
ESD	Electro Static Discharge
ESR	Equivalent Series Resistance
FFD	Full Function Device (ZigBee)
FIA	Flash Information Area
GPIO	General Purpose I/O (pins)
HF	High Frequency (24MHz)
I ² C	Inter-Integrated Circuit bus
IDE	Integrated Development Environment
IF	Intermediate Frequency
IP3	Third order Intermodulation Product
ISR	Interrupt Service Routine
kB	Kilobyte
kbps	kilobits/second
LF	Low Frequency
LNA	Low Noise Amplifier
LQI	Link Quality Indicator
MAC	Medium Access Control
MSL	Moisture Sensitivity Level
MspS	Mega samples per second
O-QPSK	Offset-Quadrature Phase Shift Keying
PA	Power Amplifier
PER	Packet Error Rate
PHY	Physical Layer
PLL	Phase-Locked Loop
POR	Power-On-Reset

Acronym/Abbreviation	Meaning
PSD	Power Spectral Density
PSRR	Power Supply Rejection Ratio
PTI	Packet Trace Interface
PWM	Pulse Width Modulation
RoHS	Restriction of Hazardous Substances
RSSI	Receive Signal Strength Indicator
SFD	Start Frame Delimiter
SIF	Serial Interface
SPI	Serial Peripheral Interface
UART	Universal Asynchronous Receiver/Transmitter
VCO	Voltage Controlled Oscillator
VDD	Voltage Supply

12 References

1. IEEE 802.15.4-2003 (standards.ieee.org/getieee802/download/802.15.4-2003.pdf)
2. IEEE 802.11g (standards.ieee.org/getieee802/download/802.11g-2003.pdf)
3. Bluetooth Specification v1.2 (www.bluetooth.org/spec)
4. ZigBee Specification v1.1 (www.zigbee.org; document number 053474r07)
5. ZigBee Security Services Specification v1.0 (www.zigbee.org; document number 03322r13)
6. Ember EM260 Reference Design (www.ember.com)

© 2006 Ember Corporation. All rights reserved.

The information in this document is subject to change without notice. This document is believed to be accurate and reliable, but the statements contained herein are presented without express or implied warranty.

EmberNet, EmberZNet, and Ember are trademarks of Ember Corporation. All other trademarks are the property of their respective holders.