



# EM35x Breakout Board Technical Specification

The Ember EM35x Breakout Board contains the hardware peripherals for the development and deployment of a low-data-rate, low-power ZigBee application on the EM300 series System-on-Chips (SoCs). The SoC is part of the four-layer (FR4-based) module that connects to the EM35x Breakout Board through the board-to-board connectors. The EM35x Breakout Board hardware stimuli include a temperature sensor, two buttons, a piezo buzzer, two LEDs, and a 2" x 2" through-hole prototyping area. In addition, the EM35x Breakout Board contains a USB transceiver with USB connector, a RS-232 transceiver with DB-9 connector, Data Emulation Interface (DEI), InSight Port (ISP) programming interface, and regulated power planes. Revision B0 and later of the EM35x Breakout Board include an optional interface to 2MB external DataFlash in support of the ZigBee OTA Profile for over-the-air (OTA) application bootloader purposes.

You can obtain the EM35x Breakout Board voltage supply from one of four sources: InSight Adapter or ISA3 (via the InSight Port), external VDC supply, USB port, or AAA battery pack. The various voltage supplies offer a degree of flexibility when testing different network topologies.

This document provides the technical specification for the EM35x Breakout Board. It describes the board-level interfaces as well as the key performance parameters. In addition, it provides the necessary information for developer to validate their application designs using the EM35x Breakout Board.

## New in this Revision

Updated to reflect latest revision (B2) of hardware.

## Contents

Breakout Board Features .....	2
Components .....	4
Power supply and distribution .....	4
Deep sleep testing of the Ember module.....	7
ZigBee application peripherals.....	7
Serial communication for EM35x SC1 UART .....	9
InSight data emulation interface (J28) .....	11
EM35x Module interface connector (J21).....	11
Prototyping area .....	14
EM35x Breakout Board Schematic .....	15



---

## Breakout Board Features

The EM35x Breakout Board offers:

- Configurable hardware support for application development
  - Temperature sensor (connects to EM35x GPIO)
  - Two buttons (connect to EM35x GPIO)
  - Piezo buzzer (connect to EM35x GPIO)
  - Two LEDs (connect to EM35x GPIO)
- RS-232 transceiver with DB-9 connector for serial communication (with hardware (HW) handshake support)
- USB transceiver with USB connector (Type B)
- 2MB external DataFlash for ZigBee OTA Profile support
- Control Interface for the EM35x Radio Communications Module (RCM)
  - RCM RESET button
  - Voltage Supply connection (VBRD)
- 2" x 2", 0.1" pitch prototyping area
- 26-pin, 0.1" pitch, dual-row logic-analyzer shrouded connector
- 10-pin, 0.05" pitch, dual-row InSight Port connector
- 12-pin, 0.1" pitch, dual-row, InSight data emulation interface (DEI) with configuration header
- 14-pin, 0.05" pitch, single-row along with a 19-pin 0.05" pitch, single-row, board-to-board connector for the module
- Selection pins for DC power source selection (either external DC power supply, USB, InSight Adapter, or AAA battery pack). LEDs indicate which power supply has been selected.
- 2-pin module VDC pin for connection of an ammeter for module current measurements
- 2-pin jumpers for each of the HW application peripherals, buzzer, buttons, piezo, temperature sensor, and LEDs
- 3-pin selection jumpers for connection to the EM35x UART (SC1). The selection jumpers route signals (RXD, TXD, nRTS, and nCTS) to either an USB transceiver, RS-232 transceiver, or allow access to the TTL levels.

Table 1 lists the DC electrical characteristics of the EM35x Breakout Board.

**Table 1. DC electrical characteristics**

Parameter	Min.	Typ.	Max.	Unit
VDD supply				
External DC Supply (J1 / J32)	4		20 <sup>1</sup>	V
USB Host	4.5	5		V
InSight Adapter	3.1	3.3V	3.5	V
Battery	2.1		3.6	
External DC supply (J3.2)	3.1	3.3	3.5	V
Current draw (peripherals)				
Piezo buzzer			10	mA
Buttons (enabled)			6	mA
Temperature sensor (enabled)			5	mA
Current draw (miscellaneous)				
RS-232 transceiver			4	mA
USB transceiver			15	mA
LDO distribution			10	mA
Operating temperature	0		+ 55	C

<sup>1</sup> Maximum external DC supply voltage is 15V for revisions B1 and earlier of the EM35x Breakout Board. See Ember Document 120-0089-000: *Errata EM35x Breakout Board Technical Specification* for more information.

## Components

Figure 1 illustrates the components on layer 1 (top side).

Figure 1. Assembly print for layer 1

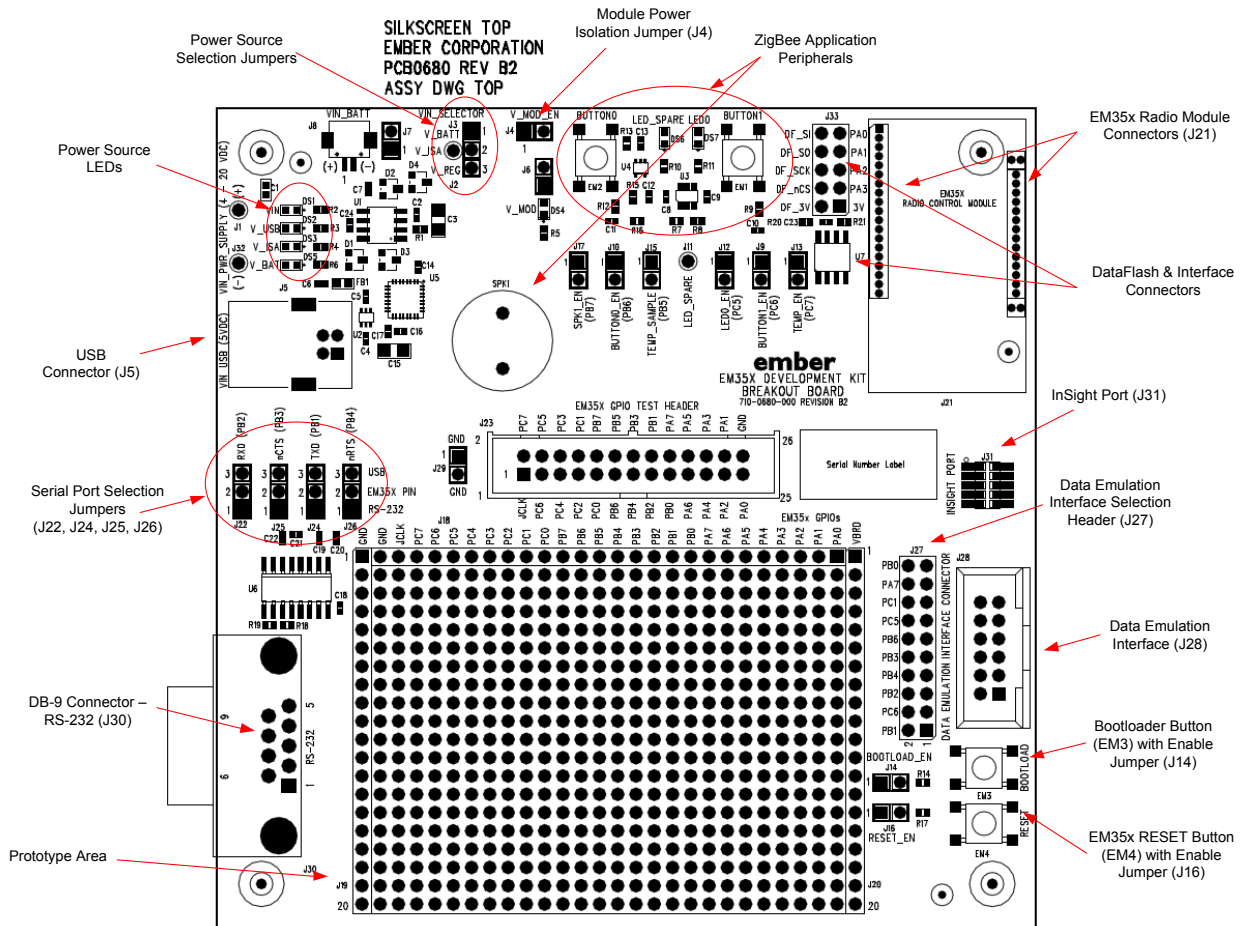

### Power supply and distribution

The EM35x Breakout Board can be powered from one of five sources:

- 4V to 20V External DC Power supply (Positive connected J1 and Ground connected to J32)
- Battery pack connector (J8)
- USB Host (J5, via Wall wart or PC connection)
- InSight Adapter (via InSight Port, J31)
- 2.1 to 3.6V External DC Power supply (Positive connected to J3.2 and Ground connected to J32)

The EM35x Breakout Board contains power source selection jumpers (J2 and J3) which allows only one DC source to power the board. This eliminates the possibility of

overcurrent resulting from power supply contention. Table 2 illustrates the connection scheme and LED indication for each power source.

Table 2: Power Supply connections

Power Source	Selection Scheme (J2 and J3)	LED Indicator
<b>High Voltage External supply (4V to 20V)</b>  <i>Connect VDD to J1 and GND to J32.</i>		VPS <input checked="" type="checkbox"/> VUSB <input type="checkbox"/> VISA <input type="checkbox"/> VBAT <input type="checkbox"/>
<b>USB Host</b>  <i>Connect USB cable to J5.</i>		VPS <input type="checkbox"/> VUSB <input checked="" type="checkbox"/> VISA <input type="checkbox"/> VBAT <input type="checkbox"/>
<b>InSight Adapter</b>  <i>Connect ISA3 to J31.</i>		VPS <input type="checkbox"/> VUSB <input type="checkbox"/> VISA <input checked="" type="checkbox"/> VBAT <input type="checkbox"/>
<b>Battery pack</b>  <i>Connect AAA battery pack (supplied by Ember).</i>		VPS <input type="checkbox"/> VUSB <input type="checkbox"/> VISA <input type="checkbox"/> VBAT <input checked="" type="checkbox"/>

Power Source	Selection Scheme (J2 and J3)	LED Indicator
<b>Low Voltage External DC supply (3.1 to 3.5)</b>  <i>Connect directly to J3.2 with Ground connected to J32.</i>		VPS <input type="checkbox"/> VUSB <input type="checkbox"/> VISA <input type="checkbox"/> VBAT <input type="checkbox"/>

### External DC power supply (J1 and J32 or J3.2 and J32)

The EM35x Breakout Board allows two easy to use connections to an external power supply.

- The first connection (Low Voltage) allows for a 3.1 to 3.5VDC external supply to be connected to J3.2 (positive) and J32 (Ground). The power supply should be able to source up to 250mA at the set voltage. When using a power supply in this mode, there should be no jumpers on J2 or J3 as shown in Table 2.
- The second connection (High Voltage) allows for a 4V to 20VDC external supply to be connected to J1 (positive) and J32 (Ground). The power supply should be able to source up to 300mA at the set voltage. When using a power supply in this mode, there should be a jumper connecting J3.3 and J3.2 as shown in Table 2.

### Battery connector (J8)

The 2-pin, keyed battery connector (Hirose, P/N: DF13-2P-1.25H(50)) allows for connection to a DC power supply or battery pack. The EM35x Breakout Board is shipped with a 2-AAA battery pack with appropriate mating connector for easy attachment. Batteries are sold separately. When using a battery pack, a jumper must be connected between J3.1 and J3.2 as shown in Table 2.

### InSight Port (J8)

The EM35x Breakout Board can also be powered from an InSight Adapter (ISA3). To enable this power supply, simply connect the ISA3 to the InSight Port (J8) and connect the power selection jumper between J2 and J3.2 as shown in Table 2. In addition, the ISA3 selection toggle switch must be put in the INT position. The ISA3 provides a target voltage of 3.3V and sources as much as 250 mA. See Ember Document 120-2010-000: *InSight Adapter Technical Specification* for more details on the ISA3.

**Note:** If the ISA3 is connected directly to the InSight Port on the Module, the jumper at J4 must be connected as well as the jumper across J2 and J3.2.

### USB Host (J5)

The EM35x Breakout Board can also be powered by a USB Host (PC or Ember-supplied USB power supply). To operate in this mode, a USB Host must be connected to J5 and the power selection jumper must be connected between J3.2 and J3.3 as shown in Table 2.

---

### Deep sleep testing of the Ember module

To allow for accurate deep sleep current measurements, the EM35x Breakout Board isolates the module VDD power supply from the regulated power domain on the EM35x Breakout Board. The only connection point between the module power supply and the EM35x Breakout Board supply is through the VMOD\_EN header (J4).

By isolating the module power supply in this manner, an ammeter can be placed across J4 to monitor the current sourced to the module. To perform accurate deep sleep measurements, configure the EM35x Breakout Board as follows:

- Remove J4 and place ammeter across this jumper.
- Remove J6 so the V\_MOD LED DS4 is not driven. If supplying voltage by J8 battery connector, also remove J7 so the V\_BATT LED DS5 is not driven.
- Remove J33 jumpers to isolate DataFlash IC from circuit.
- Issue "shutdown" in nodetest.
- Once command is issued and node is asleep, remove J22 and J24-J26 (UART jumpers).
- Make sure the InSight Port cable, DEI cable, and RS-232 cable are all detached from the EM35x Breakout Board.

This connection scheme offers the highest degree of power supply flexibility. Wake the EM35x from deep sleep by pressing either Button 0 or Button 1.

**Note:** The use of virtual UART port 4900 is not recommended when interfacing to nodetest for deep sleep testing, because this does not allow for proper configuration of the EM35x for deep sleep measurements. Therefore, use either pass-through UART port 4901, USB, or RS-232 to interface to the nodetest application.

### ZigBee application peripherals

As previously mentioned, the EM35x Breakout Board offers six peripherals to assist in ZigBee application development including:

- Temperature sensor
- Two (2) "normally open" buttons
- 4kHz piezo buzzer
- Two (2) LEDs
- External DataFlash

Each peripheral connects to an EM35x GPIO through a two-pin peripheral header. Because each peripheral header on the EM35x Breakout Board ships with a jumper in place, the peripherals default to "HW Enabled." If application development does not require the peripheral, simply remove the jumper.

**Note:** Each peripheral consumes power. Be sure to factor this into the current consumption equations when testing the module in deep sleep mode or if using the battery pack to power the EM35x Breakout Board.

#### Temperature sensor (U4)

The temperature sensor is an off-the-shelf component from National Semiconductor (MFG P/N: LM20BIM7). The temperature sensor requires an enable signal to be asserted

---

(active high) prior to generating an analog voltage proportional to the ambient temperature of the EM35x Breakout Board. Therefore, two EM35x GPIO signals, PC7 and PB5, are routed to pin 2 of peripheral headers J13 and J15, respectively.

- PC7 enables the temperature sensor when asserted (active high), when a jumper is installed at J13.
- PB5 contains the analog temperature information from the sensor, when it is enabled and a jumper is installed at J15.

Due to the EM35x ADC voltage reference at 1.2V, the temperature sensor output is scaled to between 0 and 1.2V through a resistive voltage divider. If you want to connect a temperature sensor from a different manufacturer, scale the output in a similar manner.

The EM35x Breakout Board is shipped with a jumper installed at J13 and J15. If the jumpers are removed, a different compatible device can be attached to pin 2 of both J13 and J15.

For more information on the temperature sensor, refer to its datasheet ([www.national.com/pf/LM/LM20.html](http://www.national.com/pf/LM/LM20.html)).

#### Buttons (EM1, EM2)

Two programmable, normally-open buttons are provided for software debugging and application development. When either button is pressed, the connected net is driven low. A single-pole RC filter minimizes the effects of switching noise.

These buttons map to the backchannel button commands as follows:

- EM2: controlled by the `button 0` command
- EM1: controlled by the `button 1` command

For information about the `button` command, see Ember Document 120-4020-000: *EM35x Development Kit User Guide*.

Two EM35x GPIO signals, PB6 and PC6, are routed from the EM35x Module to pin 2 of peripheral headers J9 and J10, respectively. In the default configuration of the EM35x Breakout Board, jumpers are positioned across J9 and J10 to enable buttons EM1 and EM2, respectively. If the jumpers are removed, different compatible devices can be attached to pin 2 of breakout headers J9 and J10 instead of the buttons.

#### Buzzer (SPK1)

A programmable buzzer is provided for software debugging and application development. An EM35x GPIO signal, PB7, is routed to pin 2 of peripheral header J17. In the default configuration of the EM35x Breakout Board, a jumper is positioned across J17 to enable use of the buzzer. The buzzer installed on the EM35x Breakout Board is from CUI (MFG P/N: CEP-1160). For more information on the buzzer, refer to its datasheet (<http://products.cui.com/getPDF.aspx?fileID=1264>).

#### LEDs (DS6 and DS7)

The EM35x Breakout Board contains two LEDs for software debugging and application development. Each LED is buffered (non-inverting) to allow for connection to any EM35x GPIO. One EM35x GPIO, PC5, is routed to pin 2 of header J12. To turn on DS7 (RED) from the EM35x RCM, install a jumper at J12, configure PC5 as an output and drive it

low. To turn on DS6 (GREEN), make a physical connection between an unused EM35x GPIO and J11 (single pin header). Once this is done, then that GPIO must be configured as an output and driven low to illuminate DS6.

### External DataFlash (U7)

The external DataFlash is an off-the-shelf component from Atmel (MFG P/N: AT45DB021D-SSH-B). The DataFlash is used in cases where ZigBee OTA Profile application bootloader is required. Note that the DataFlash is included on EM35x Breakout Board revision B0 and later. The DataFlash is connected to the EM35x RCM via jumper block J33. The EM35x Breakout Board is shipped with jumpers installed in a disconnected state at J33. If all five jumpers are installed properly at J33, the external DataFlash connects to the EM35x for application bootloading. Figure 2 illustrates the J33 jumper configuration for the DataFlash interface.

Figure 2. Jumper for DataFlash connections

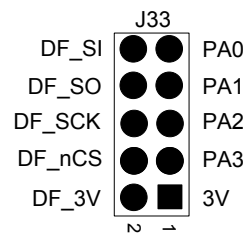

For more information on the DataFlash, refer to its datasheet ([www.atmel.com/dyn/resources/prod\\_documents/doc3638.pdf](http://www.atmel.com/dyn/resources/prod_documents/doc3638.pdf)).

### Serial communication for EM35x SC1 UART

To enhance the software development experience, access to the EM35x SC1 UART is available directly from the EM35x Breakout Board or by telnetting into port 4901 of an ISA3 connected to an Ethernet network. On the EM35x Breakout Board, it is available as RS-232, USB and TTL-compliant signal levels.

To minimize current consumption and allow for the different configuration options, the EM35x Breakout Board individually routes the EM35x SC1 UART signals TXD (EM35x PB2), RXD (EM35x PB1), nRTS (EM35x PB3), and nCTS (EM35x PB4) to pin 2 of headers J22, J24, J25 and J26 respectively. TTL-level access to these UART signals is available at pin 2 of these headers. To route the UART signals to the USB transceiver, connect the jumpers between pins 3 and 2 to each of the headers. Placing the jumpers across pins 1 and 2 route the UART signals to the RS-232 transceiver. To access the EM35x UART SC1 with an ISA3, remove the jumpers on J22, J24, J25 and J26 and place them on the InSight DEI jumper connector (J27) as summarized below and shown in Figure 3.

- TXD: J27.1 to J27.2
- RXD: J27.5 to J27.6
- nRTS: J27.7 to J27.8
- nCTS: J27.9 to J27.10

Each jumper configuration is shown in Table 3.

Table 3: Serial Communication Selection Jumpers

UART Path	Selection Scheme (J22, J25, J24 and J26)
EM35x SC1 to USB	<p>TXD (PB2)    nRTS (PB3)    RXD (PB1)    nCTS (PB4)</p> <p>3    3    3    3    USB 2    2    2    2    EM35x Pin 1    1    1    1    RS-232</p> <p>J22    J25    J24    J26</p>
EM35x SC1 to TTL	<p>TXD (PB2)    nRTS (PB3)    RXD (PB1)    nCTS (PB4)</p> <p>3    3    3    3    USB 2    2    2    2    EM35x Pin 1    1    1    1    RS-232</p> <p>J22    J25    J24    J26</p>
EM35x SC1 to RS-232	<p>TXD (PB2)    nRTS (PB3)    RXD (PB1)    nCTS (PB4)</p> <p>3    3    3    3    USB 2    2    2    2    EM35x Pin 1    1    1    1    RS-232</p> <p>J22    J25    J24    J26</p>
EM35x SC1 over InSight Adapter (ISA3)  <i>Connect ISA3 DEI cable to J28.</i>	<p>TXD (PB2)    nRTS (PB3)    RXD (PB1)    nCTS (PB4)</p> <p>3    3    3    3    USB 2    2    2    2    EM35x Pin 1    1    1    1    RS-232</p> <p>J22    J25    J24    J26</p>

**Note:** To connect to the EM35x UART over an ISA3, the ISA3 must be connected to an Ethernet connection. It can be accessed by issuing “Serial 1” within the Console view of the InSight Desktop or by telnetting to Port 4901.

Figure 3. Jumper settings required for EM35x SC1 UART access by InSight Adapter

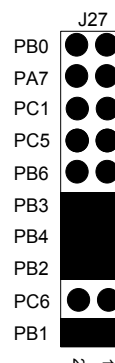

### InSight data emulation interface (J28)

The 12-pin, dual-row, InSight data emulation interface contains 10 EM35x GPIO signals, as well as voltage (VBRD) and ground (GND) connections. When connected to the InSight Adapter, the connector provides additional debug features to software developers.

One feature involves the port 4901 UART connection via ISA. To enable the UART connection to the EM35x UART signals, install four jumpers on J27 as shown in Figure 3.

Another feature involves manipulation of BUTTON0 and BUTTON1 GPIO signals. To enable GPIO manipulation of BUTTON0 and BUTTON1, install jumpers on J27 at PB6 and PC6, respectively.

### EM35x Module interface connector (J21)

Two single-row, 0.05" pitch, connectors make up the EM35x module interface to the EM35x Breakout Board. In addition, two single-row, guide connectors assist with connecting the EM35x module to the EM35x Breakout Board. The board-to-board connector scheme allows access to all EM35x GPIO as well as nRESET and the JCLK signals. The connector is illustrated in Figure 4, while the dimensions are listed in Figure 5.



functions of the GPIO connector, refer to Ember Document 120-035X-000: *EM35x Datasheet*.

**Table 4. Pinout and signal names of the interface connector**

Pin #	Signal name	Direction <sup>2</sup>	Connector	Description
1	GND	Power	J21A	Ground Connection
2	PC5	I/O	J21A	EM35x GPIO
3	PC6	I/O	J21A	EM35x GPIO
4	PC7	I/O	J21A	EM35x GPIO
5	PA7	I/O	J21A	EM35x GPIO
6	PB3	I/O	J21A	EM35x GPIO
7	nRESET	I/O	J21A	Active low chip reset (internal pull-up on EM35x)
8	PB4	I/O	J21A	EM35x GPIO
9	PA0	I/O	J21A	EM35x GPIO
10	PA1	I/O	J21A	EM35x GPIO
11	PA2	I/O	J21A	EM35x GPIO
12	PA3	I/O	J21A	EM35x GPIO
13	GND	Power	J21A	Ground connection
14	PA4	I/O	J21A	EM35x GPIO
15	PA5	I/O	J21A	EM35x GPIO
16	PA6	I/O	J21A	EM35x GPIO
17	PB1	I/O	J21A	EM35x GPIO
18	PB2	I/O	J21A	EM35x GPIO
19	GND	Power	J21A	Ground connection
20	GND	Power	J21B	Ground connection
21	JCLK	Input	J21B	JTAG interface, serial clock
22	PC2	I/O	J21B	EM35x GPIO
23	PC3	I/O	J21B	EM35x GPIO
24	PC4	I/O	J21B	EM35x GPIO
25	PB0	I/O	J21B	EM35x GPIO
26	PC1	I/O	J21B	EM35x GPIO
27	PC0	I/O	J21B	EM35x GPIO
28	PB7	I/O	J21B	EM35x GPIO
29	PB6	I/O	J21B	EM35x GPIO
30	PB5	I/O	J21B	EM35x GPIO
31	GND	Power	J21B	Ground connection
32	VDD	Power	J21B	2.1 to 3.6V Module Power Domain
33	GND	Power	J21B	Ground connection
34	NC	N/A	J21C	Not connected; guide pin
35	NC	N/A	J21C	Not connected; guide pin
36	NC	N/A	J21D	Not connected; guide pin

Pin #	Signal name	Direction <sup>2</sup>	Connector	Description
37	NC	N/A	J21D	Not connected; guide pin

<sup>2</sup> with respect to the RCM

### Prototyping area

The 2.8" x 2" (0.1" pitch) prototyping area on the EM35x Breakout Board offers software developers an extra degree of flexibility. As shown in Figure 4, it allows access to VBRD, GND, and each of the 24 EM35x GPIOs. Therefore, you can solder any sensor or input device to the prototyping area and connect it to the EM35x GPIO for development and debugging.

As shown in Figure 6, the leftmost column is connected to GND and the rightmost column to VBRD. The top row is connected to the EM35x GPIOs. Included in the top row are additional GND and JCLK connections. The remainder of the array is available for application development.

Figure 6. EM35x Breakout Board prototyping area

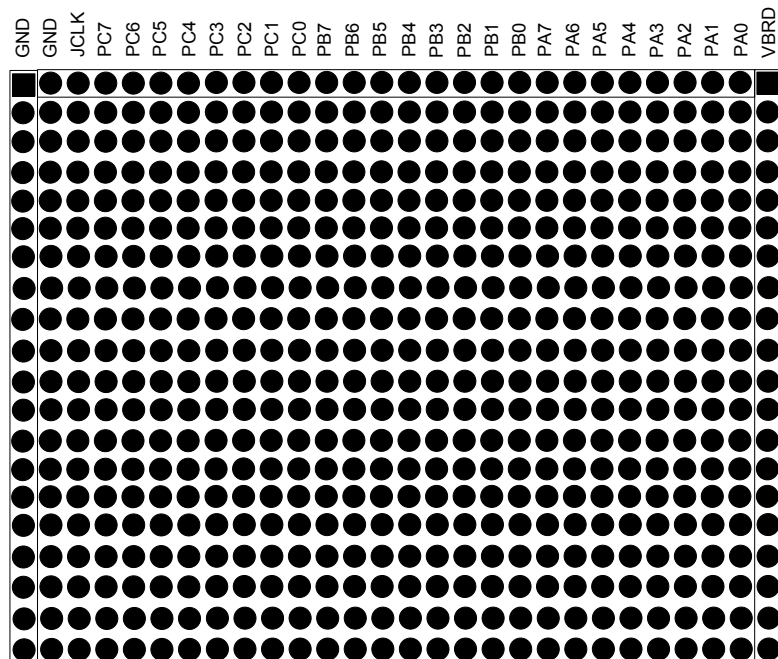

### **EM35x Breakout Board Schematic**

The EM35x Breakout Board schematic is included at the end of this document.

### **After Reading This Document**

If you have questions or require assistance with the procedures described in this document, contact Ember Customer Support. The Ember Customer Support portal provides a wide array of hardware and software documentation such as FAQ's, reference designs, user guides, application notes, and the latest software available to download. To obtain support on all Ember products and to gain access to the Ember Customer Support portal, visit [http://www.ember.com/support\\_index.html](http://www.ember.com/support_index.html).

# EM35X Development Kit Breakout Board

<u>Sheet</u>	<u>Details</u>
1	COVER SHEET
2	POWER MANAGEMENT, MANUFACTURING
3	APPLICATIONS CIRCUITS, BREADBOARD
4	EM35X RCM CONNECTORS, USER INTERFACES, DATAFLASH
5	NOTES

	Ember Corporation, 25 Thomson Pl, Boston, MA 02210 TEL: 617-951-0200, FAX: 617-951-0999 www.ember.com	
DWG	<b>SCH0680</b>	REV <b>B2</b>
TITLE	<b>EM35X DEVELOPMENT KIT BREAKOUT BOARD</b>	
PAGE	<b>COVER SHEET</b>	
<small>The information in this document is subject to change without notice. The statements, configurations, technical data and recommendations in this document are believed to be accurate and reliable, but are presented without express or implied warranty. The information in this document is the proprietary and confidential property of Ember Corporation and is privileged. No part of the drawing or information may be duplicated or otherwise used without the express permission of Ember Corporation.</small>		
SIZE B	DATE: 18-08-2011_15:14	SHEET: 1 of 5

## POWER SUPPLY, DC, 4V to 20V

\* Place J1 close to J31

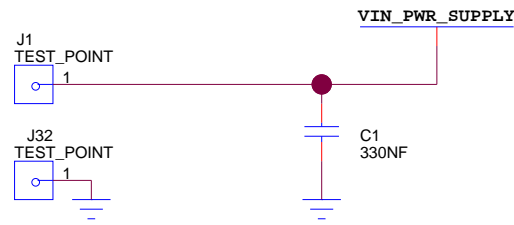

## USB / VIN\_PWR\_JACK Down Conversion

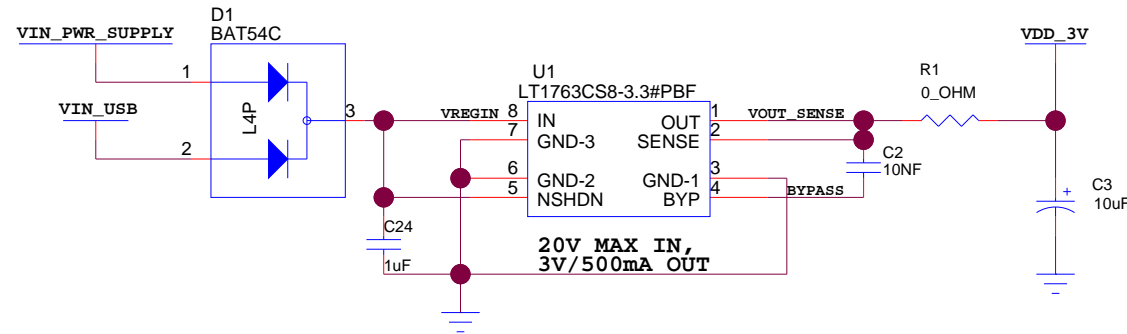

## Breakout Board and Module Power Selector

Headers J2 and J3 allow the user to select the power source. There are five possible power sources for the Breakout board.

1. External 3V Supply (Connect directly to J3.2)
2. External Regulated supply from 4V to 20V (Connect shorting jumper between J3 pins 2.3)
3. Ember battery pack with 2 AAA (Connect shorting jumper between J3 pins 1.2)
4. USB Bus Powered (Connect shorting jumper between J3 pins 2.3)

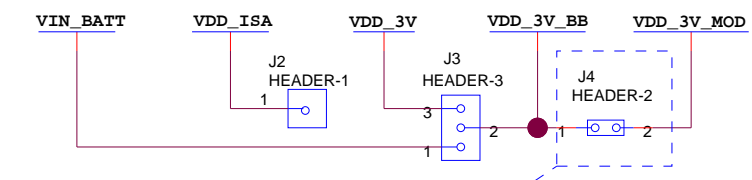

The shorting jumper at J4 can be replaced with a current meter to measure module current draw

## BATTERY CONNECTOR (2 AAA), 1.5V to 3.1V

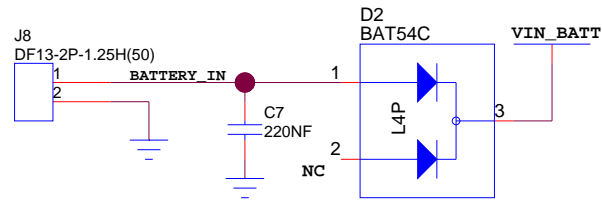

## Power Indicator LEDs

\* Remove J6 when performing a Deep Sleep Test

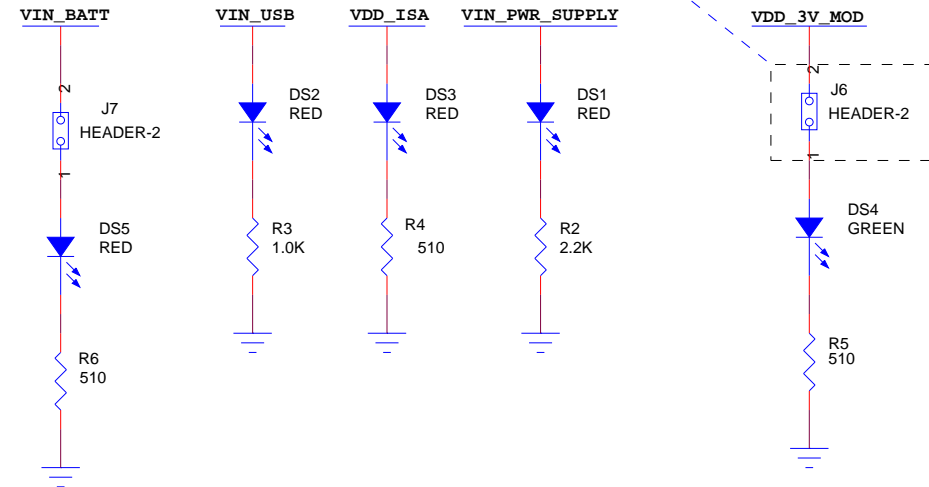

## PCB Information

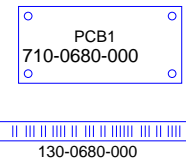

## Fiducials Mounting Holes

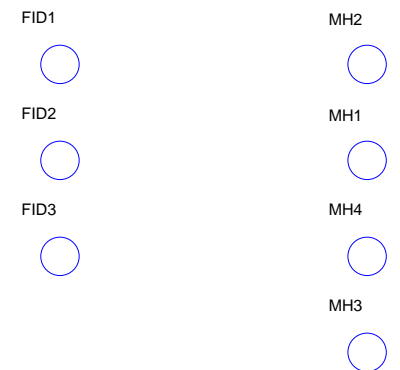

## USB CONNECTION (TYPE B) 5V

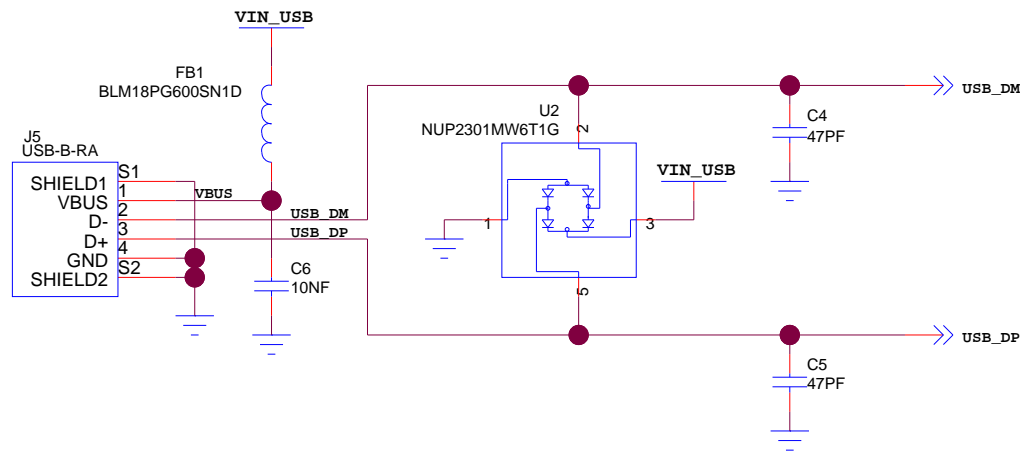

## Test Equipment GND Connection

J29 is placed close to J23

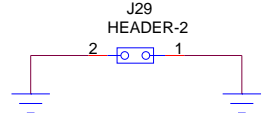

## ESD Suppression (Power Supply)

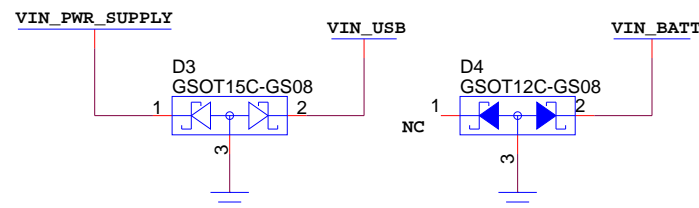

## Shorting Jumpers

\*\*Refer to assembly documentation for information on shipping state of jumpers\*\*

Place shorting jumpers across the following connector pins;

- J2 and J3.2
- J4
- J6
- J9
- J10
- J11
- J12
- J13
- J14
- J15
- J16
- J17
- J22.1 (unconnected)
- J24.1 (unconnected)
- J25.1 (unconnected)
- J26.1 (unconnected)
- J27.1 and J27.2
- J27.5 and J27.6
- J33.1 to J33.2
- J33.3 to J33.4
- J33.5 to J33.6
- J33.7 to J33.8
- J33.9 to J33.10

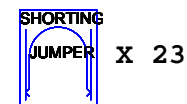

<b>ember</b>		Ember Corporation, 25 Thomson Pl, Boston, MA 02210 TEL: 617-951-0200, FAX: 617-951-0999 www.ember.com	
DWG	<b>SCH0680</b>		REV <b>B2</b>
<b>TITLE EM35X DEVELOPMENT KIT BREAKOUT BOARD</b>			
<b>PAGE POWER MANAGEMENT, MANUFACTURING</b>			
The information in this document is subject to change without notice. The statements, configurations, technical data and recommendations in this document are believed to be accurate and reliable, but are presented without express or implied warranty. The information in this document is the proprietary and confidential property of Ember Corporation and is privileged. No part of the drawing or information may be duplicated or otherwise used without the express permission of Ember Corporation.			
SIZE B	DATE:	18-08-2011_15:14	SHEET: 2 of 5

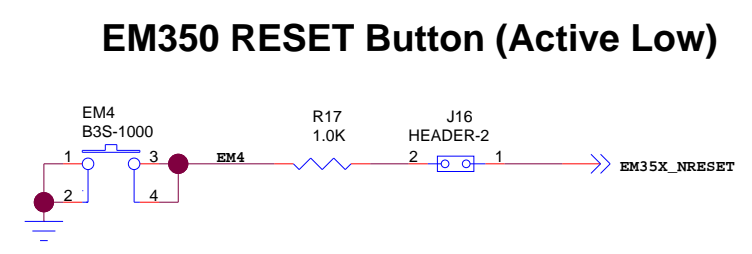
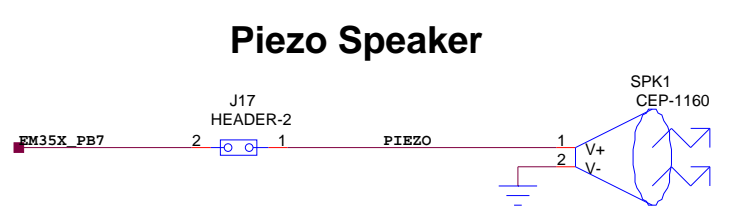
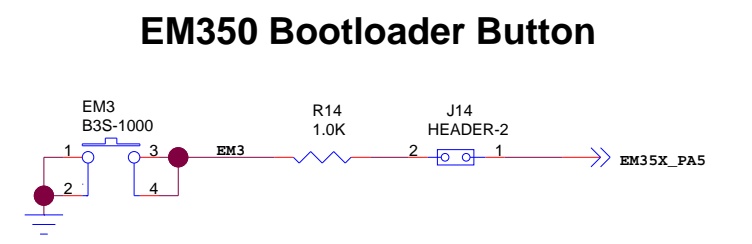
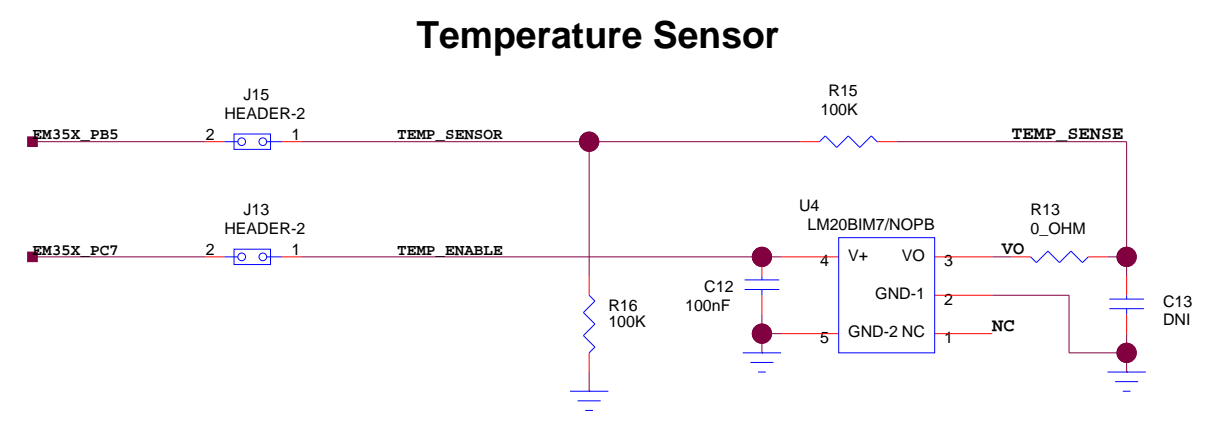
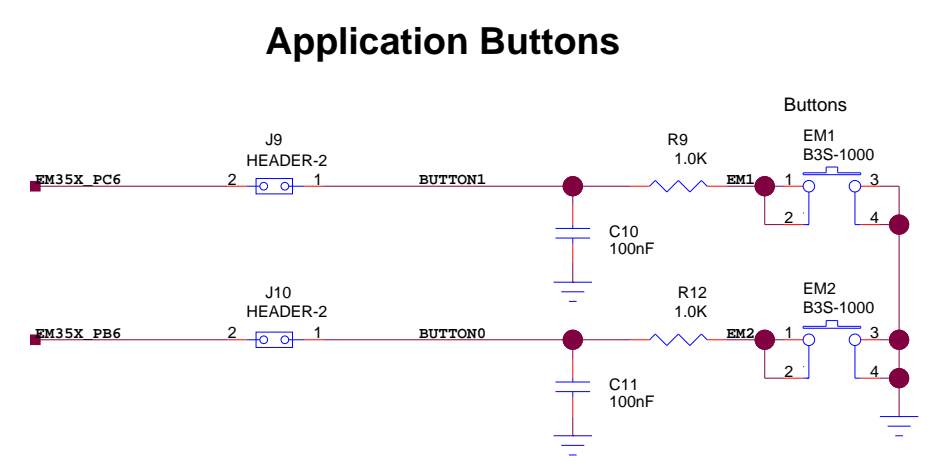
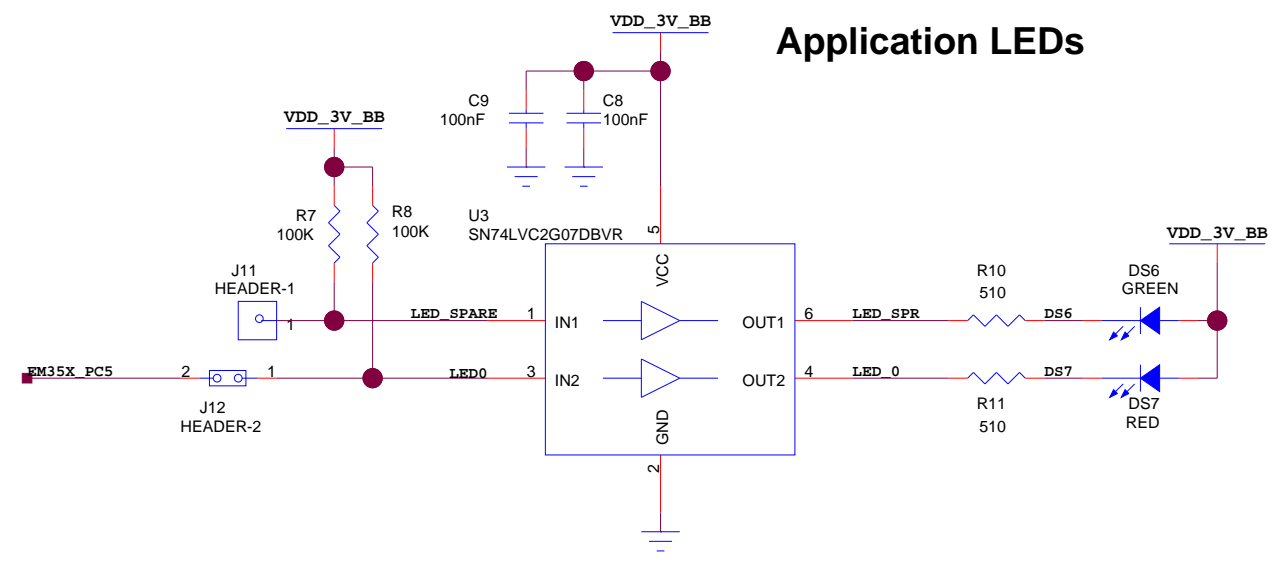

### Peripheral Scratch Pad (0.1" pitch)

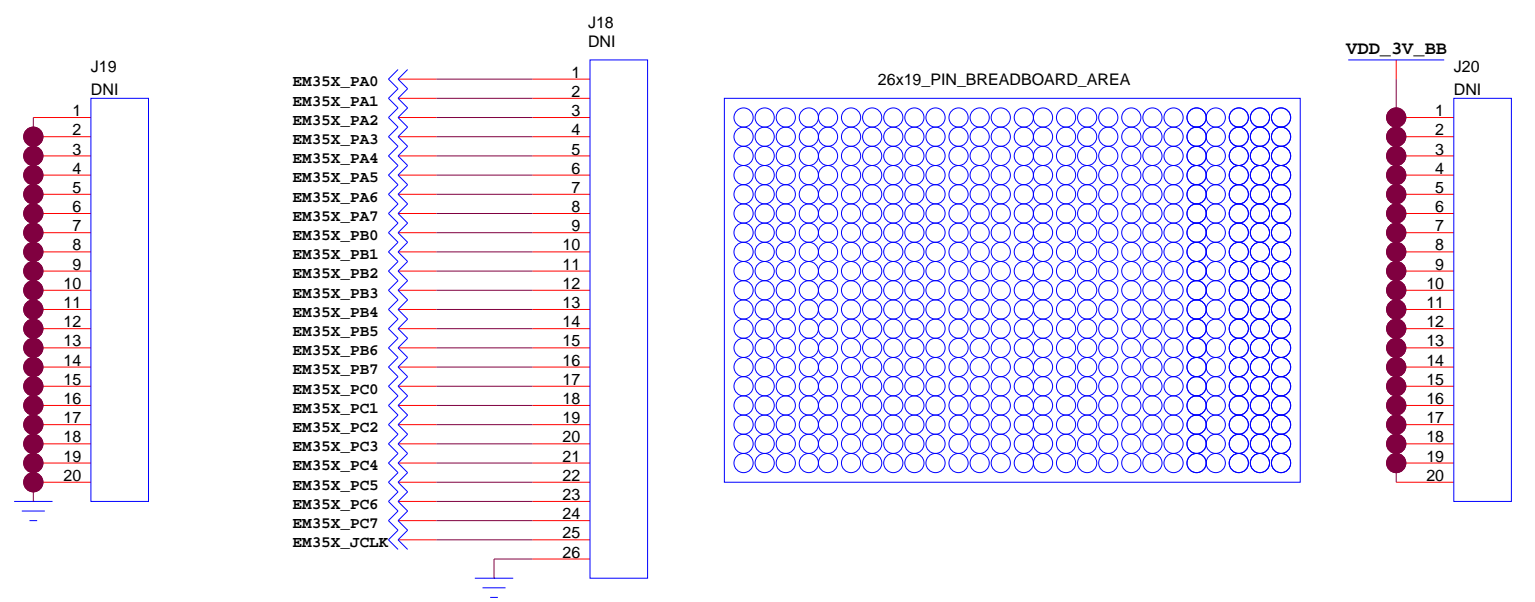

### 26-Pin, Dual Row Test Connector

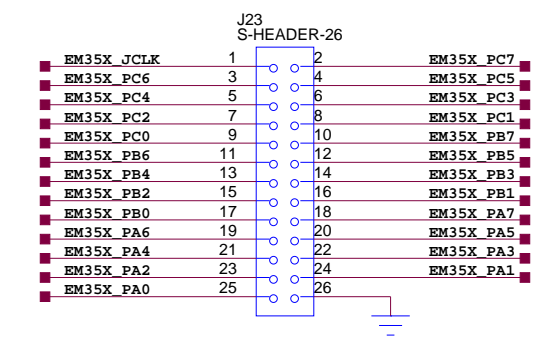

<b>ember</b>		Ember Corporation, 25 Thomson Pl, Boston, MA 02210 TEL: 617-951-0200, FAX: 617-951-0999 www.ember.com	
DWG	<b>SCH0680</b>		REV <b>B2</b>
<b>TITLE EM35X DEVELOPMENT KIT BREAKOUT BOARD</b>			
<b>PAGE APPLICATIONS CIRCUITS, BREADBOARD</b>			
The information in this document is subject to change without notice. The statements, configurations, technical data and recommendations in this document are believed to be accurate and reliable, but are presented without express or implied warranty. The information in this document is the proprietary and confidential property of Ember Corporation and is privileged. No part of the drawing or information may be duplicated or otherwise used without the express permission of Ember Corporation.			
SIZE B	DATE: 18-08-2011_15:14	SHEET: 3 of 5	

### EM35X RCM Interface Header

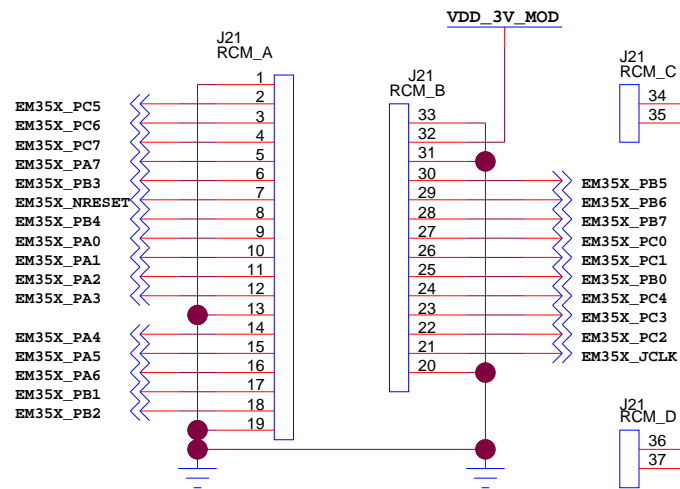

### EM35X DEI

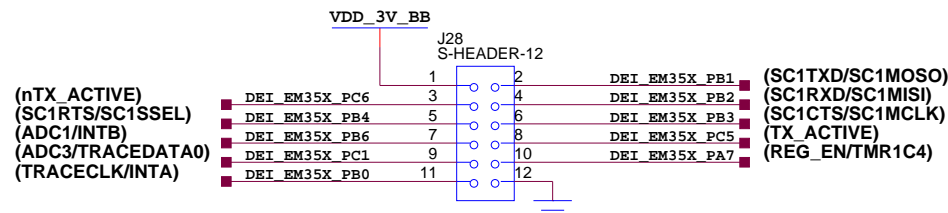

### EM35X DEI JUMPERS

Should be place near J28

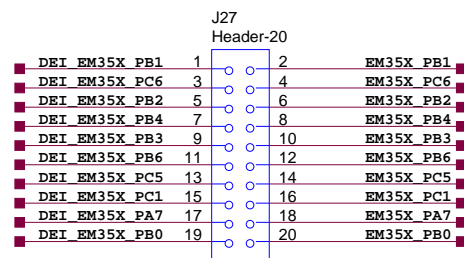

### InSight Port (ISP)

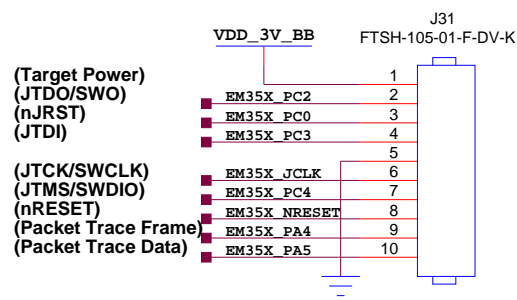

### USB / UART IC

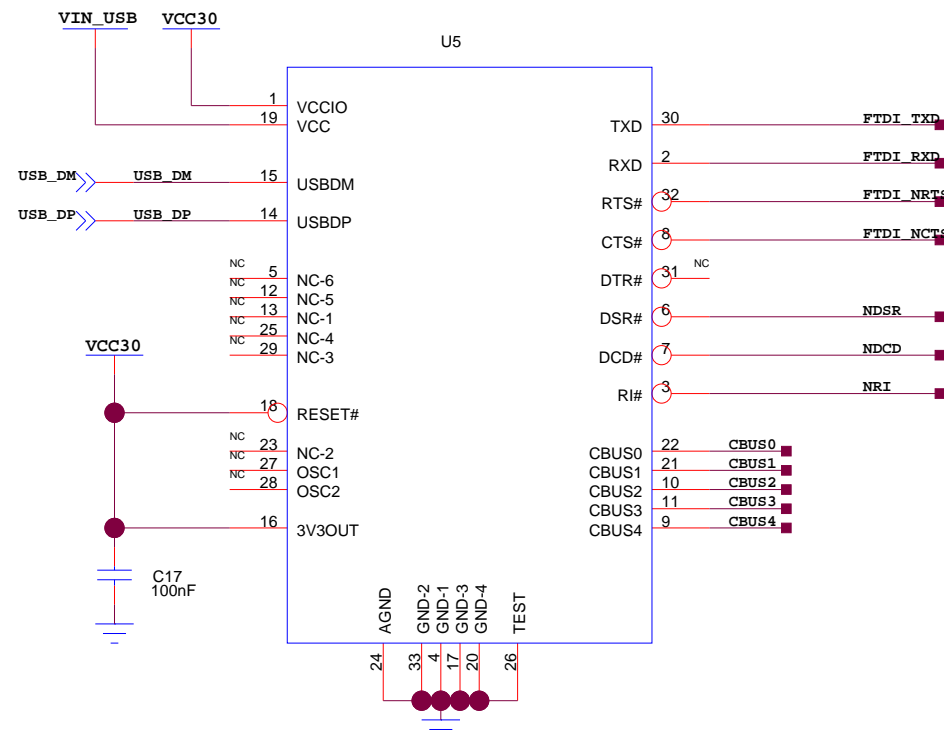

### USB IC Decoupling

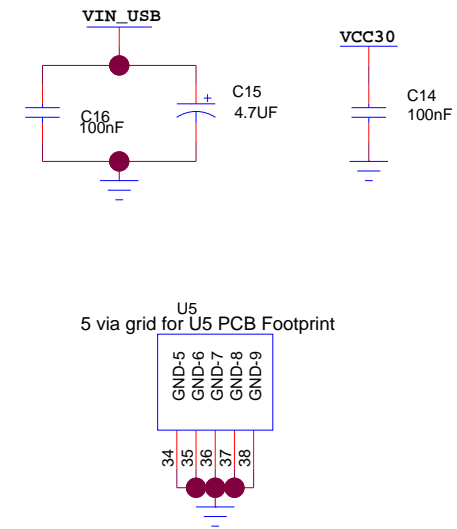

### FTDi GPIO Test Points

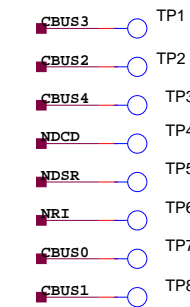

### TTL to RS-232 Transceiver

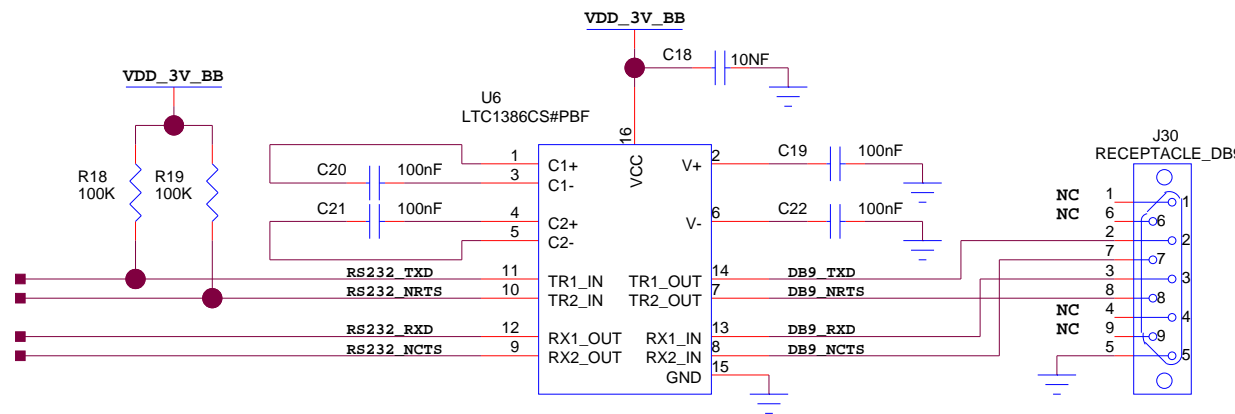

### DataFlash

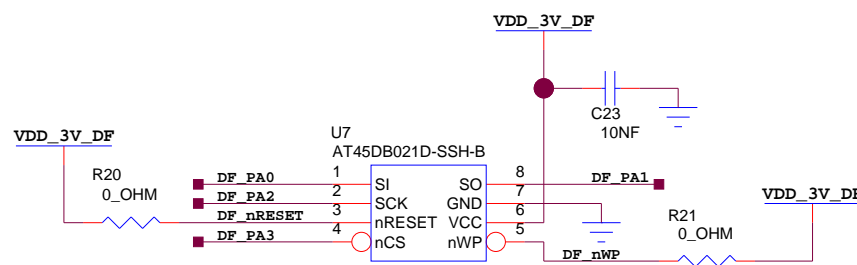

Voltage range of the AT45DB021D is 2.7V to 3.6V  
Radio Modules which are expected to operate at voltages below 2.7V will require a DC toDC up-converter supply  
Input data on SI is always latched on the rising edge of SCK  
Output data on SO is always clocked out on the falling edge of SCK

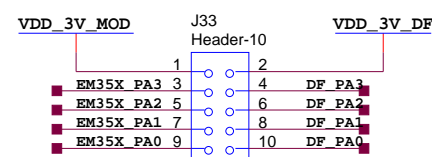

### USB/RS-232 Selector

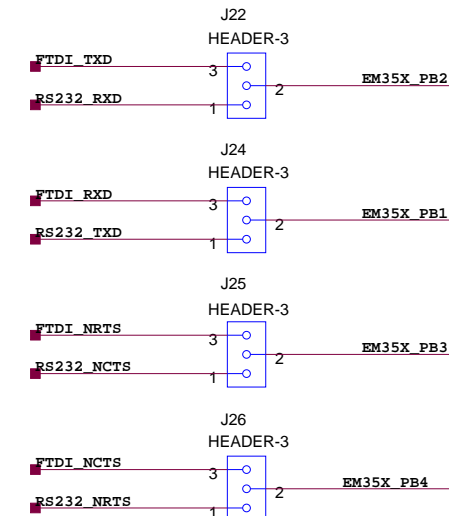

<b>ember</b>		Ember Corporation, 25 Thomson Pl, Boston, MA 02210 TEL: 617-951-0200, FAX: 617-951-0999 www.ember.com	
DWG	<b>SCH0680</b>		REV <b>B2</b>
<b>TITLE EM35X DEVELOPMENT KIT BREAKOUT BOARD</b>			
<b>PAGE EM35X RCM CONNECTORS, USER INTERFACES</b>			
The information in this document is subject to change without notice. The statements, configurations, technical data and recommendations in this document are believed to be accurate and reliable, but are presented without express or implied warranty. The information in this document is the proprietary and confidential property of Ember Corporation and is privileged. No part of the drawing or information may be duplicated or otherwise used without the express permission of Ember Corporation			
SIZE B	DATE: 18-08-2011_15:14	SHEET: 4 of 5	

**SCHEMATIC NOTES:**

-- Version A0 --  
 \*Released: December 8, 2009  
 \*Initial version released, Version A0 (initial draft)

-- Version B0 --  
 \*Released: January 13, 2010  
 \*Changes from A0 include:  
 1. Added U7, DataFlash  
 2. Added C23, 10nF  
 3. Added R20, 0 Ohm  
 4. Added R21, 0 Ohm  
 5. Added J33, 10 pin shorting plug header  
 6. Added SJ19 - SJ23, Shorting Plugs

-- Version B2 --  
 \*Released: August 19, 2011  
 \*Changes from B0 schematic and B1 BOM include:  
 1. Added C24 1uF cap to U1 regulator, incorporating ECO C00273 into design  
 2. Changed D3 from GSOT12C to GSOT15C  
 3. Updated shorting jumper notes  
 4. Updated C3 to a lower ESR cap for better regulator stability

**PCB LAYOUT NOTES:**

-- Version A0 --  
 \*Released: December 8, 2009  
 \*Initial version released, Version A0 (initial draft)

-- Version B0 --  
 \*Released: January 13, 2010  
 \*Changes from A0 include:  
 1. Added U7, DataFlash, plus routes  
 2. Added C23, 10nF, plus routes  
 3. Added R20, 0 Ohm, plus routes  
 4. Added R21, 0 Ohm, plus routes  
 5. Added J33, 10 pin shorting plug header, plus routes  
 6. Changed silkscreen text at J22 to display "RXD (PB2)"  
 7. Changed silkscreen text at J24 to display "TXD (PB1)"  
 8. Changed silkscreen text at J25 to display "nCTS (PB3)"  
 9. Changed silkscreen text at J26 to display "nRTS (PB4)"  
 10. Reduced size of Ember logo, Moved it and rotated it 90 degrees

-- Version B2 --  
 \*Released: August 19, 2011  
 \*Changes from B0 layout and B1 BOM include:  
 1. Added bump-on outlines for bottom-side assembly  
 2. Added C24 1uF cap to U1 regulator  
 3. Updated drill sizes for some through-hole decals  
 4. Updated DB-9 connector footprint from vertical to right-angle  
 5. Fixed board outline dimensioning error

<b>ember</b>		Ember Corporation, 25 Thomson Pl, Boston, MA 02210 TEL: 617-951-0200, FAX: 617-951-0999 www.ember.com	
DWG	<b>SCH0680</b>		REV <b>B2</b>
<b>TITLE EM35X DEVELOPMENT KIT BREAKOUT BOARD</b>			
PAGE		<b>REVISION NOTES</b>	
The information in this document is subject to change without notice. The statements, configurations, technical data and recommendations in this document are believed to be accurate and reliable, but are presented without express or implied warranty. The information in this document is the proprietary and confidential property of Ember Corporation and is privileged. No part of the drawing or information may be duplicated or otherwise used without the express permission of Ember Corporation			
SIZE A	DATE:	18-08-2011_15:14	SHEET: 5 of 5

Copyright © 2009 - 2011 Ember Corporation

All rights reserved. Neither this publication nor any part thereof can be copied, photocopied, reproduced, translated, or converted to any electronic or machine-readable form in whole or in part without prior written approval of Ember Corporation. This documentation is furnished under license and can be used or copied only in accordance with the terms of such license.

The content of this documentation is furnished for informational use only, is subject to change without notice, and does not represent a commitment or guaranty by Ember Corporation. The statements, configurations, technical data, and recommendations in this document are believed to be accurate and reliable as of the time of publication, but Ember Corporation assumes no responsibility or liability for any errors or inaccuracies that may appear in this documentation. DOCUMENTATION IS PROVIDED "AS IS" AND ALL EXPRESS OR IMPLIED CONDITIONS, REPRESENTATIONS AND WARRANTIES, INCLUDING ANY IMPLIED WARRANTY OF MERCHANTABILITY, FITNESS FOR A PARTICULAR PURPOSE OR NONINFRINGEMENT, ARE DISCLAIMED. Users are responsible for their applications and for the use of any products specified in this document.

Title, ownership, and all rights in copyrights, patents, trademarks, and other intellectual property rights embodied in Ember Corporation's Products and any copy, portion, or modification thereof, shall not transfer to Purchaser or its customers and shall remain in Ember Corporation and its licensors.

No source code rights are granted to Purchaser or its customers with respect to any Ember software. Purchaser agrees not to copy, modify, alter, translate, decompile, disassemble, or reverse engineer Ember hardware (including without limitation any embedded software) or attempt to disable any security devices or codes incorporated in Ember hardware. Purchaser shall not alter, remove, or obscure any printed or displayed legal notices contained on or in Ember hardware.

Ember is a trademark of Ember Corporation. All other trademarks are the property of their respective holders.

