



# EM260 Breakout Board Technical Specification

## SPI/UART, 128kB Version

The Ember EM260 SPI/UART 128kB Breakout Board contains the hardware stimulus for the development and deployment of a low-data-rate, low-power ZigBee application on a host microcontroller (with 128kB of Flash) communicating with the EM260 SPI/UART radio communication module (RCM). The Breakout Board allows for either a SPI or UART interface to the EM260, selectable via a toggle switch. The four-layer (FR4) Breakout Board features an Atmel host microcontroller (ATmega128L), a temperature sensor, two application buttons, a piezo buzzer, two application LEDs, and a 2" x 2.6" through-hole prototyping area. In addition, it contains a USB interface, InSight data emulation interface, regulated power planes with indicator LEDs, and direct attachment to the EM260 SPI/UART RCM. These features allow for proper development of an EM260 application.

The Breakout Board's voltage supply can be obtained from one of four sources: EM260 SPI/UART RCM (via the InSight Port), 12V DC, USB bus power, or battery pack. This feature offers a degree of flexibility when testing different network topologies.

### New in this Revision

Schematics republished to improve graphic quality.

Document cross-references updated.

### Contents

Features .....	2
Components .....	4
Power supply and distribution .....	4
Application peripherals .....	6
Configuration switches .....	7
Configuring communication paths.....	8
Serial communication with the host microcontroller (SPI mode).....	8
Serial communication with the EM260 (UART mode).....	10
InSight data emulation interface (J7) .....	11
EM260 SPI/UART RCM interface connectors (J1) .....	12
Separation of module power and board power.....	13
USB GPIO test points .....	14
Prototyping area .....	14
Breakout Board Schematic .....	15



**Warning:** Please clearly identify the EM260 hardware version you are using. The EM260 SPI/UART RCM (130-0461-000) mates with either the EM260 SPI/UART Breakout Board (130-0471-000) or the EM260 SPI/UART 128kB Breakout Board (130-0473-000). The EM260 SPI-only RCM (130-0460-000) mates with the EM260 SPI-only Breakout Board (130-0470-000). These hardware versions are not compatible with each other. See Figure 1 to identify which hardware version you are using—SPI-only is on the left and SPI/UART is on the right. If you are using the SPI-only version, please contact Ember Support if you have any issues with your hardware.

Figure 1 shows the SPI-only Breakout Board on the left and the SPI/UART Breakout Board on the right.

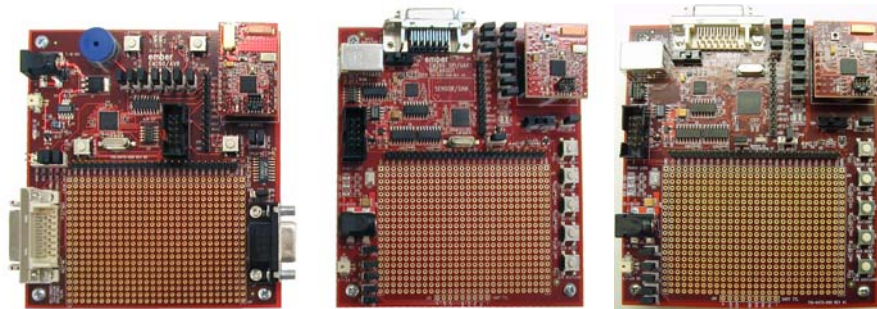

Figure 1. SPI-only (left) vs. SPI/UART 32kB (middle) vs. 128kB (right)

## Features

The EM260 SPI/UART 128kB Breakout Board offers:

- Host microcontroller, ATmega128L from Atmel, with 128kB Flash and 8kB RAM
- AVR ISP and JTAG shrouded connectors for programming and debug
- Configurable hardware support for application development
  - Temperature sensor
  - Two buttons
  - Piezo buzzer
  - Two LEDs
- Selectable USB connector with RS-232 transceiver
- EM260 SPI/UART RCM reset button
- Host microcontroller reset button
- Host microcontroller bootloader button
- 2" x 2.6", 0.1" pitch prototyping area
- 26-pin, 0.1" pitch, single-row header for access to all host GPIO signals
- 2 6-pin, 0.1" pitch, single-row EM260 SPI/UART RCM connectors
- 2 6-pin, 0.1" pitch, single-row headers for access to EZSP signals
- 9-pin, 0.1" pitch, single-row header footprint for access to 3.3V TTL-compliant UART signals
- 26-pin, low-profile InSight data emulation interface with configuration header
- Automatic DC power source selection (12V DC wall wart, 5V USB bus power, or AAA battery pack)

- Power indicator LEDs for 12V DC wall wart, 5V USB bus power, and board power
- Jumper separation of module and board power for accurate module current measurements

Table 1 lists the DC electrical characteristics of the EM260 SPI/UART Breakout Board.

Table 1. DC electrical characteristics

Parameter	Min.	Typ.	Max.	Unit
VDD supply				
From battery	2.1	3	3.6	V
From USB	3.3	5	5.25	V
From DC jack	7	12	16	V
Active Current draw (host microcontroller)		13		mA
Current draw (peripherals)				
Piezo buzzer			10	mA
Buttons (enabled)			6	mA
Temperature sensor (enabled)			5	mA
Current draw (miscellaneous)				
USB RS-232 transceiver		15		mA
TPS2105 (power distribution switch)			35	μA
LDO distribution			75	μA
Operating temperature	- 40		+ 85	C

## Components

Figure 2 illustrates the components on layer 1 (top side).

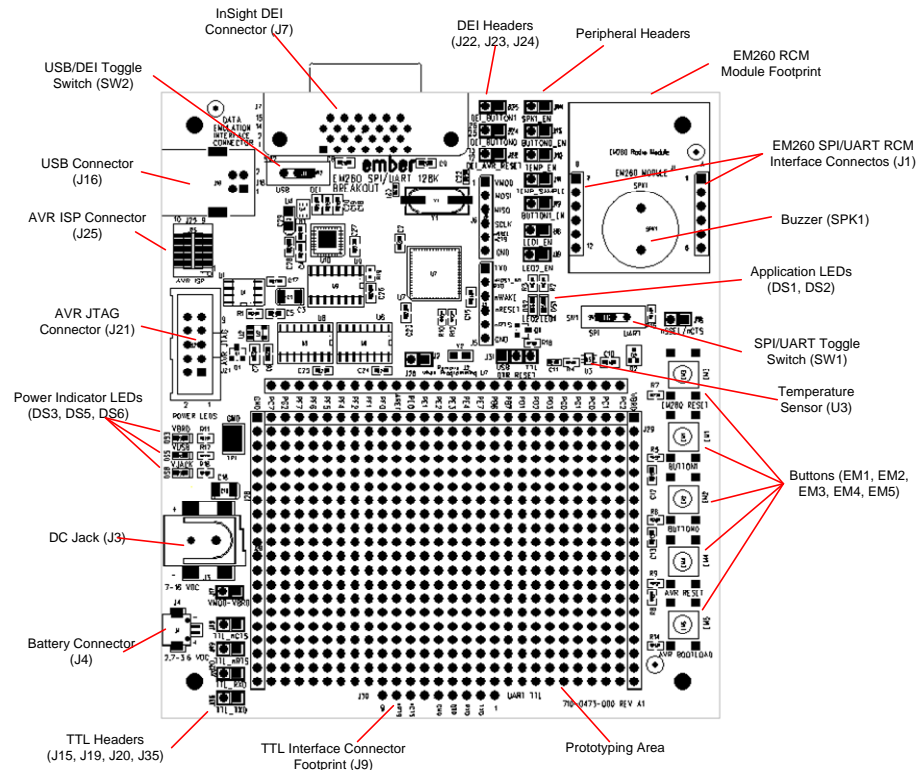

Figure 2. Top side components

### Power supply and distribution

The EM260 SPI/UART Breakout Board can be powered from one of four sources:

- DC jack (J3) with 12V DC power supply
- USB connector (J16)
- Battery pack connector (J4)
- The InSight Adapter (via InSight Port and attached to EM260 SPI/UART RCM)

The EM260 SPI/UART 128kB Breakout Board contains power source selection logic to choose the DC jack power supply over the USB connection, and either the DC Jack or USB connection over the battery pack. However, it cannot automatically sense when the attached RCM is sourcing power via the InSight Adapter. Therefore, be careful to make sure power is only being sourced from one supply.

**Caution:** Although Ember recommends that only one power supply be connected to the EM260 SPI/UART 128kB Breakout Board, the board does contain voltage-sensing logic to properly switch between the battery connector and the DC jack or USB connector.

### DC jack (J3)

The DC jack on the EM260 SPI/UART 128kB Breakout Board allows for a robust connection (5,000 cycles) to the 12V DC power supply that is shipped with the EM260 SPI/UART Breakout Board. The 2.1 x 5.5mm jack from CUI, Inc. (MFG P/N: PJ-105A-SMT) is rated to 16V DC at 2.5A. The center pin of the jack is +V with shroud connected to the GND plane.

### USB connector (J16)

The USB connector on the EM260 SPI/UART 128kB Breakout Board allows for a robust connection (1,500 cycles) to the USB cable that is shipped with the EM260 SPI/UART Breakout Board. The USB port of the PC provides 5V USB bus power to this connector. The connector is from Molex (MFG P/N: 67068-8110) and is rated to 30V at 1.5A.

When powering the EM260 SPI/UART 128kB Breakout Board via USB, Ember recommends that you adhere to the following USB bus power rules, according to the FTDI FT232RQ datasheet (download from <http://www.ftdichip.com/Products/ICs/FT232R.htm>):

1. The device must draw <100mA on plug-in to USB.
2. The device must draw <500µA in suspend mode.
3. If the device draws >100mA, use a CBUS pin as #PWREN to adhere to rules 1 and 2.
4. If the device draws >100mA, it cannot be plugged into a bus-powered USB hub.
5. No device can draw >500mA from the USB bus (on-board regulator tops out at 500mA).

### Battery connector (J4)

The 2-pin battery connector (Hirose, P/N: DF13-2P-1.25H(50)) allows for connection to a DC power supply or battery pack. The EM260 SPI/UART 128kB Breakout Board is shipped with a 2-AAA battery pack with appropriate mating connector for easy attachment.

### InSight Adapter (through the EM260 SPI/UART RCM)

The EM260 SPI/UART 128kB Breakout Board can also be powered from the InSight Adapter when an EM260 SPI/UART RCM is attached. To enable this power supply, the InSight Adapter selection toggle switch must be put in the INT position (as described in Ember document 120-2002-000, *InSight Adapter Technical Specification*), and the InSight port cable must be attached to the EM260 SPI/UART RCM. The InSight Adapter is able to source 50 mA of current at 3.0V. Therefore, use care when enabling application peripherals on the Breakout Board.

**Note:** When powering the EM260 SPI/UART 128kB Breakout Board in this manner, disconnect the battery pack, 12V DC power supply, and USB.

---

### Power indicator LEDs (DS3, DS5, DS6)

The EM260 SPI/UART 128kB Breakout Board contains three power indicator LEDs:

- 3V board power (DS3)
- 5V USB (DS5)
- 12V DC jack (DS6)

The board power LED DS3 will be on regardless of the power source selected.

### Application peripherals

As previously mentioned, the EM260 SPI/UART 128kB Breakout Board offers six peripherals to assist in application development. These include:

- Temperature sensor
- Two “normally open” buttons
- 4kHz piezo buzzer
- Two LEDs

Each peripheral connects to a host microcontroller GPIO through a two-pin peripheral header. Because each peripheral header on the EM260 SPI/UART 128kB Breakout Board ships with a jumper in place, the peripherals default to “HW Enabled.” If application development does not require the peripheral, simply remove the jumper. Note that each peripheral consumes power, so factor this into the current consumption equations for battery consumption (if using a battery to power the Breakout Board).

### Temperature sensor (U3)

The temperature sensor is an off-the-shelf component from National Semiconductor (MFG P/N: LM20BIM7). The temperature sensor requires an enable signal to be asserted (active high) prior to generating an analog voltage proportional to the ambient temperature of the EM260 SPI/UART 128kB Breakout Board. Therefore, two host microcontroller GPIO signals, PF1 and PC7, are routed to pin 2 of peripheral headers J11 and J10, respectively.

- PC7 enables the temperature sensor when asserted (active high), when a jumper is installed at J10.
- PF1 contains the analog temperature information from the sensor, when it is enabled and a jumper is installed at J11.

The EM260 SPI/UART 128kB Breakout Board is shipped with jumpers installed at J10 and J11. If the jumpers are removed, a different compatible device can be attached to pin 2 of both J10 and J11.

For more information on the temperature sensor, please refer to its datasheet (at [www.national.com/pf/LM/LM20.html](http://www.national.com/pf/LM/LM20.html)).

### Buttons (EM1, EM2)

Two programmable, normally open buttons are provided for software debugging and application development. When either button is pressed, the connected net is driven low. A single-pole RC filter minimizes the effects of switching noise.

These buttons map to the backchannel button commands as follows:

- EM2: controlled by the `button 0` command
- EM1: controlled by the `button 1` command

For information about the `button` command, refer to Ember document 120-4027-000, the *EM260 User's Guide*.

Two GPIO signals, PD1 (Button 0) and PE4 (Button 1), are routed from the host microcontroller to pin 2 of peripheral headers J13 and J12, respectively. In the default configuration of the EM260 SPI/UART 128kB Breakout Board, jumpers are positioned across J12 and J13 to enable buttons EM1 and EM2, respectively.

If the jumpers are removed, different compatible devices can be attached to pin 2 of breakout headers J12 and J13 instead of the buttons.

#### Buzzer (SPK1)

A programmable buzzer is provided for software debugging and application development. A GPIO signal, PB7, is routed to pin 2 of peripheral header J14. In the default configuration of the carrier board, a jumper is positioned across J14 to enable use of the buzzer. The buzzer installed on the EM260 SPI/UART 128kB Breakout Board is from CUI (MFG P/N: CEP-1160). For more information on the buzzer, refer to its datasheet (<http://products.cui.com/getPDF.aspx?filename=CEP-1160.pdf>).

#### LEDs (DS1 and DS2)

The EM260 SPI/UART 128kB Breakout Board contains two LEDs for software debugging and application development. Two host microcontroller GPIOs, PC0 and PC1, are routed to pin 2 of headers J8 and J9, respectively. To turn on DS1 and DS2 from the EM260 SPI/UART RCM, install jumpers at J8 and J9, respectively; an active low signal is driven from the Host.

#### Configuration switches

The EM260 SPI/UART 128kB Breakout Board contains two configuration switches to allow for various modes of functionality. SW1 configures the board for either SPI or UART functionality mode, while SW2 configures the communication path to either the USB or data emulation interface (DEI) interface.

#### SPI/UART toggle switch (SW1)

The EM260 SPI/UART 128kB Breakout Board contains a toggle switch for selecting either SPI mode or UART mode. The EM260 SPI/UART RCM is shipped with the SPI EZSP application installed. The EM260 SPI/UART 128kB Breakout Board is thus shipped with SW1 in the SPI position (pin 1, left). If UART mode is desirable, program the EM260 SPI/UART RCM with the UART EZSP application and move SW1 to the UART position (pin 3, right).

#### USB/DEI toggle switch (SW2)

The EM260 SPI/UART 128kB Breakout Board contains a toggle switch for selecting either USB or DEI communication interfaces. The EM260 SPI/UART 128kB Breakout Board is shipped with SW2 in the DEI position (pin 1, right). If USB mode is desirable, move SW2 to the USB position (pin 3, left) and connect a USB cable from your PC to J16 of the Breakout Board.

### Configuring communication paths

There are various configurations for SPI or UART communication when using the EM260 SPI/UART 128kB Breakout Board. In SPI mode, the EM260 communicates with the on-board host via EZSP (SPI) and communication paths can be made to the on-board host. In UART mode, the EM260 communicates directly with an external host, while the on-board host is not in use. Figure 3 displays a table (also included on the silkscreen bottom side of the 710-0473-000 board) that details the switch and jumper settings to properly configure the board for a specific mode and communication path.

## SPI/UART CONFIGURATION TABLE

MODE, OUTPUT	SW1	SW2	REMOVE JUMPERS
SPI MODE ENABLED, USB OUTPUT	SPI	USB	J31
SPI MODE ENABLED, DEI OUTPUT	SPI	DEI	J15,J19,J31
SPI MODE ENABLED, TTL ACCESS	SPI	DEI	J15,J19,J20,J31,J35
UART MODE ENABLED, USB OUTPUT	UART	USB	NONE
UART MODE ENABLED, DEI OUTPUT	UART	DEI	J15,J19 (UNSUPPORTED)
UART MODE ENABLED, TTL ACCESS	UART	DEI	J15,J19,J20,J35

Figure 3. SPI/UART Configuration Table

The following sections provide details for each of these configurations.

### Serial communication with the host microcontroller (SPI mode)

To enhance the software development experience, access to the on-board host microcontroller UART is available directly from the EM260 SPI/UART 128kB Breakout Board or by telnetting into port 4901 of the InSight Adapter. On the EM260 SPI/UART 128kB Breakout Board, it is available as both USB RS-232 and 3.3V TTL-compliant signal levels. From the InSight Adapter, it is only available as 3.3V TTL-compliant signal levels.

The following sections describe three configuration options for SPI mode access to the serial communication of the on-board host microcontroller: two through the EM260 SPI/UART 128kB Breakout Board and one through the InSight Adapter.

#### USB RS-232 serial communication via J16

The EM260 SPI/UART 128kB Breakout Board contains a USB RS-232 transceiver (U10). To enable communication with the on-board host microcontroller UART as an RS-232 device via USB, move SW2 to the USB position. Figure 4 illustrates this connection scheme.



Figure 4. Jumper settings for SPI-mode USB RS-232 serial communication

### TTL-compatible serial communication via J20 and J35

The EM260 SPI/UART 128kB Breakout Board enables TTL-compatible communication with the on-board host microcontroller UART. Pin 2 of peripheral headers J20 and J35 expose the RXD and TXD signals from SC1 UART. Figure 5 illustrates this connection scheme.

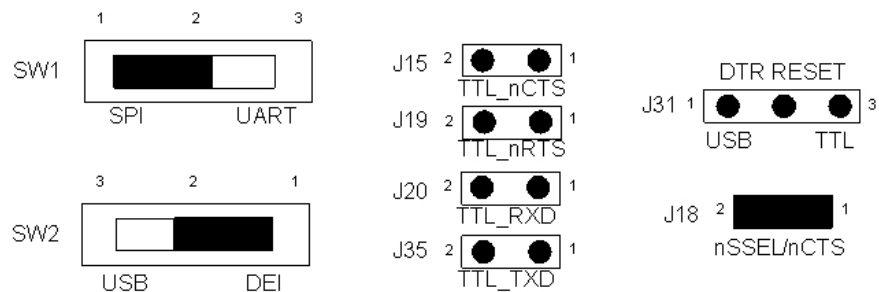

Figure 5. Jumper settings for TTL-compatible serial communication

### TTL-compatible serial communication from InSight Adapter

To access the on-board host microcontroller UART from port 4901 of the InSight Adapter:

1. Disconnect the InSight DEI cable from the InSight Adapter.
2. Move SW1 to position SPI (pin 1, left) and SW2 to position DEI (pin 1, right) as shown in Figure 6.
3. Move the InSight Adapter voltage toggle switch to the INT position.
4. Remove the secondary power source from the EM260 SPI/UART 128kB Breakout Board.

**Note:** Power must be supplied by the InSight Adapter.

5. Connect the InSight DEI cable to the InSight Adapter.

**Warning:** Because the InSight data emulation interface (DEI) is not buffered, the InSight Adapter must provide power for the EM260 SPI/UART 128kB Breakout Board and the EM260 SPI/UART RCM when using this interface.

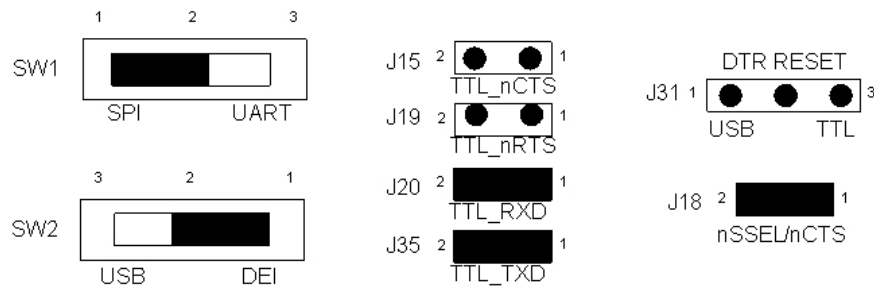

Figure 6. Jumper settings required for on-board host microcontroller UART access by InSight Adapter

### Serial communication with the EM260 (UART mode)

Access to the EM260 UART from an external host is available directly from the EM260 SPI/UART 128kB Breakout Board only, as both RS-232 and 3.3V TTL-compliant signal levels. EM260 UART via port 4901 of the InSight Adapter is not supported.

**Note:** The on-board host is not in use during UART mode.

The following sections describe two configuration options for access to the serial communication of the EM260 in UART mode, both through the EM260 SPI/UART 128kB Breakout Board.

#### USB RS-232 Serial Communication via J16

The EM260 SPI/UART 128kB Breakout Board contains a USB RS-232 transceiver (U10). To enable communication with EM260 UART as an RS-232 device via USB, move SW2 to the USB position. To enable use of DTR as a reset source to the EM260, connect the jumper at J31 to pins 1 and 2 (left) as shown in Figure 7. To use an external EM260 reset source, remove the jumper at J31 and connect the external source to middle pin 2.

Figure 7 illustrates this connection scheme.



Figure 7. Jumper settings for RS-232 serial communication

**Note:** Windows users of EZSP-UART via USB should set the FTDI device latency to 2msec. This allows for a 33% increase in application throughput. To change the device latency:

1. Run Device Manager and go to Ports (COM & LPT).
2. Select the USB Serial Port that is in use and right click to select Properties.
3. Select the Port Settings tab and then click Advanced.
4. Under BM Options, find Latency Timer (msec), and set it to 2 (default is 16).
5. Click OK to enter this change.

#### TTL-compatible serial communication via J15, J19, J20, and J35

The EM260 SPI/UART 128kB Breakout Board enables TTL-compatible communication with the EM260 UART. Pin 2 of peripheral headers J15, J19, J20, and J35 expose the nCTS, nRTS, RXD, and TXD signals from SC1 UART. To enable use of DTR as a reset source to the EM260, connect the jumper at J31 to pins 2 and 3 (right) as shown in Figure 8. To use an external EM260 reset source, remove the jumper at J31 and connect the external source to middle pin 2. Figure 8 illustrates this connection scheme.

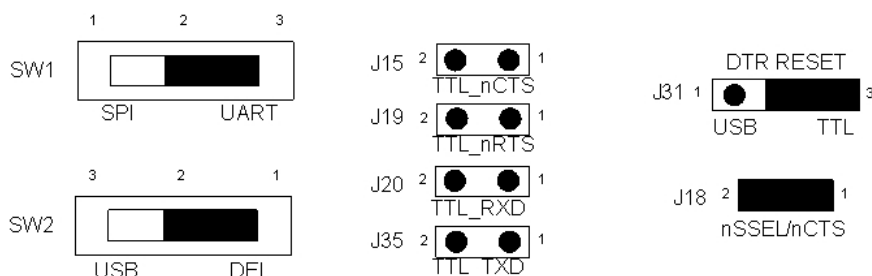

Figure 8. Jumper settings for TTL-compatible serial communication

#### InSight data emulation interface (J7)

The 26-pin, dual-row, InSight data emulation interface (DEI) connects to three GPIO and the UART of the host microcontroller. When connected to the InSight Adapter, the connector provides additional debug features to the software developer, such as button emulation, reset emulation, and the port 4901 UART connection via the InSight Adapter.

For information on using the UART connection, refer to the section “TTL-compatible serial communication from InSight Adapter” in either the “Serial communication with the host microcontroller (SPI mode)” or “Serial communication with the EM260 (UART mode)” section.

To emulate the buttons and reset functionality of the EM260 SPI/UART 128kB Breakout Board, headers must be installed on J22, J23, and J24, as shown in Figure 9.

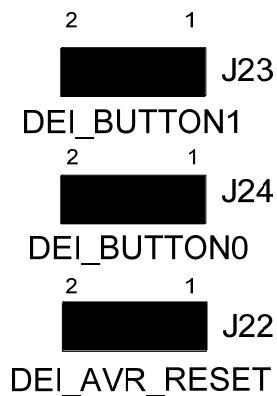

Figure 9. DEI headers for data emulation

### EM260 SPI/UART RCM interface connectors (J1)

The two 6-pin, single-row, 0.1” pitch sockets allow direct connection of the EM260 SPI/UART RCM to the EM260 SPI/UART 128kB Breakout Board. The two sockets and pinout definitions are contained in Figure 10 and Table 2, respectively. These sockets allow access to the EZSP (SPI or UART). The connectors on the EM260 SPI/UART 128kB Breakout Board are from Molex (MFG P/N: 22-28-4063).

For more information on the EZSP functionality, refer to Ember document 120-0260-000, the *EM260 Datasheet*.

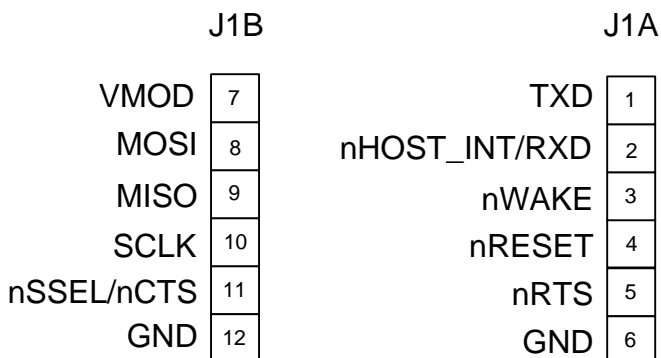

Figure 10. RCM interface connectors (J1)

Table 2. Pinout and signal names of the interface connector

Pin #	Signal name	Direction*	Description
J1A.1	TXD	O	UART transmit (from EM260 to Host)
J1A.2	nHOST_INT/RXD	O/I	Dual-purpose pin: SPI Host interrupt (from EM260 to Host) or UART receive (from EM260 to Host)
J1A.3	nWAKE	I	Wake interrupt (from Host to EM260)
J1A.4	nRESET	I	Active low chip reset (internal pull-up)
J1A.5	nRTS	O	UART ready to send (from EM260 to Host)
J1A.6	GND	Power	Ground connection
J1B.7	VMOD	Power	2.1 to 3.6V DC power supply for RCM
J1B.8	MOSI	I	SPI data, master out/slave in (from Host to EM260)
J1B.9	MISO	O	SPI data, master in/slave out (from EM260 to Host)
J1B.10	SCLK	I	SPI clock (Host to EM260)
J1B.11	nSSEL/nCTS	I	Dual-purpose pin: Active low SPI slave select (Host to EM260) or UART clear to send (from Host to EM260)
J1B.12	GND	Power	Ground connection

\* with respect to the RCM

J5 and J6 are two 6-pin headers with the signals from J1A and J1B, respectively. These two headers allow for direct access to the EM260 SPI/UART RCM EZSP.

### Separation of module power and board power

To allow for proper module current measurements, module power (VMOD) and board power (VBRD) are separated at J17. Connecting a multimeter in series with this jumper provides accurate module current measurements without factoring other currents on the VBRD power plane.

---

### USB GPIO test points

The unused USB GPIOs are brought out to test points (TP2 through TP9) on the bottom side of the EM260 SPI/UART 128kB Breakout Board. For more information on these GPIO signals, consult the FTDI FT232RQ datasheet (download from <http://www.ftdichip.com/Products/ICs/FT232R.htm>).

### Prototyping area

The 2" x 2.6" (0.1" pitch) prototyping area on the EM260 SPI/UART 128kB Breakout Board offers software developers an extra degree of flexibility. As shown in Figure 11, it allows access to VBRD, GND, and each of the 26 host microcontroller GPIOs. Therefore, you can solder any sensor or input device to the prototyping area and connect it to the GPIO for development and debugging.

As shown in Figure 11, the leftmost column is connected to GND (J28) and the rightmost column to VBRD (J29). The top row is connected to the GPIOs. Included in the top row are additional GND and VBRD connections. The remainder of the array is available for application development.

**Warning:** Because the InSight Adapter can only source up to 50mA of current, external power sources are required if any circuitry is added to the prototyping area.

Below the array is a 9-pin 0.1" pitch footprint for the UART TTL interface. You can use this as a TTL interface to either the host in SPI mode or the EM260 in UART mode. If desired, a DB-9 adapter (Winford Engineering, PN: PBC9F) can be soldered into this footprint and, along with a TTL to RS-232 converter (B&B Electronics, PN: LPT23233), can allow for RS-232 connection to a PC.

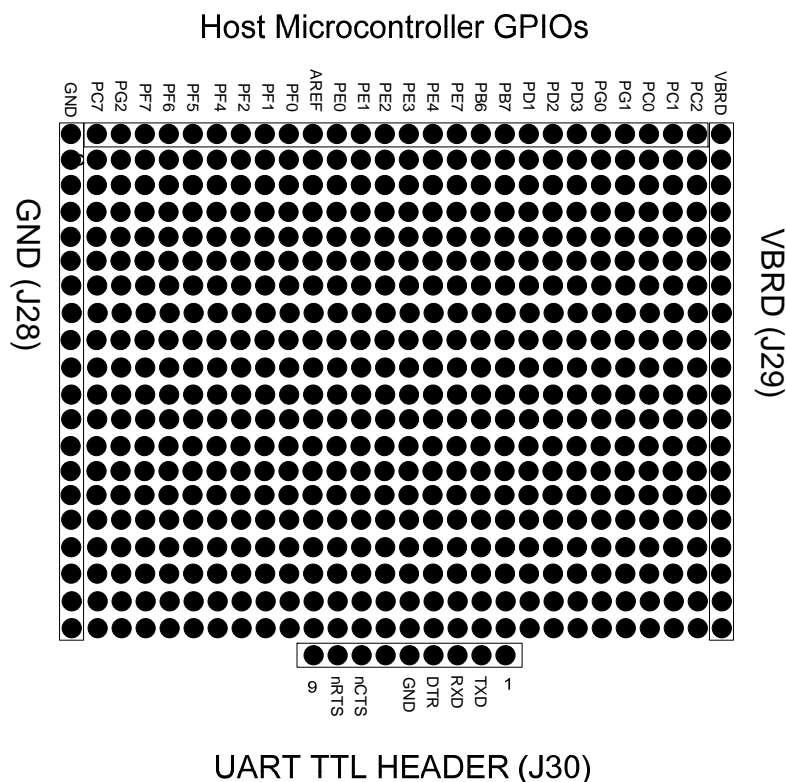

Figure 11. EM260 SPI/UART 128kB Breakout Board prototyping area

**Warning:** The maximum allowed current for the entire board (500mA) is based on the limitations of the on-board regulator. The EM260 SPI/UART 128kB Breakout Board itself normally draws approximately 50mA itself. Therefore, circuitry added to the prototyping area must not exceed 450mA.

## Breakout Board Schematic

The EM260 SPI/UART 128kB Breakout Board (0471 Version A0) schematics are included at the end of this document. Use these schematics when developing your application. The schematics include:

- Power distribution and miscellaneous circuitry.
- The host microcontroller.
- The signal flow diagram.
- The SPI/UART and USB/DEI logic.
- The USB, DEI, and TTL external interfaces.

## After Reading This Document

If you have questions or require assistance with the procedures described in this document, contact an Ember support representative at [http://www.ember.com/support\\_index.html](http://www.ember.com/support_index.html).

**POWER JACK,  
DC, 12V**

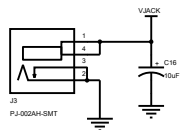

**SCHOTTKY PROTECTION**

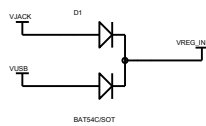

**Power Distribution**

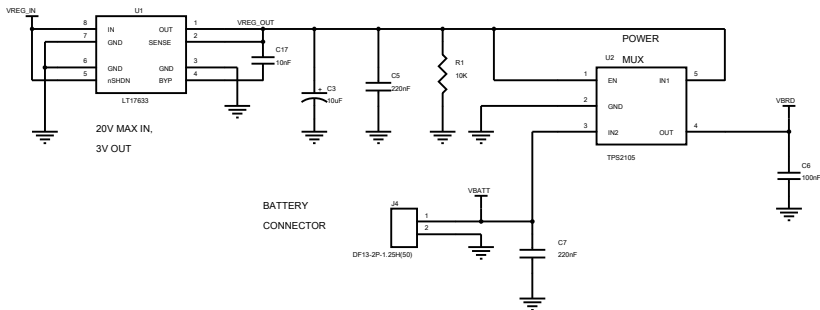

**Separation of VMOD from VBRD**



**GROUND CLIP**

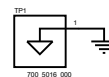

**Notes for POWER MUX (U2):**

- 1) VREG\_OUT is 3.3V when connected to an InSight Adapter or when using the 12V Wall Wart.
- 2) VBATT can be 2.1 to 3.6V, but usually it will be 3.0V
- 3) VBRD = VREG\_OUT when using a 12V Wall Wart, USB, or InSight Adapter
- 4) VBRD = VBATT when Battery connected AND both VJACK and VUSB\_BUS are not connected.

**Note, VBRD comes from either:**

- A) InSight Adapter (Extended Debug Connector) or,
- B) WALL WART or
- C) Battery Pack or
- D) USB

**Mounting Holes**

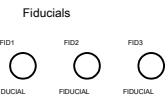

X 18

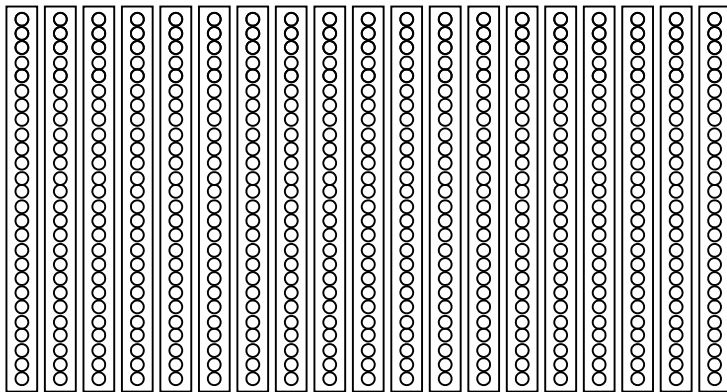

28pins Breadboard

X 19

**Power Indicator LEDs**

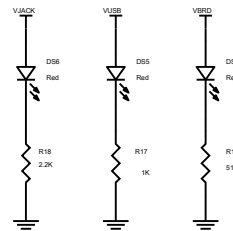

**Disclaimer**

The information in this document is subject to change without notice. The statements, configurations, technical data and recommendations in this document are believed to be accurate and reliable, but are presented without express or implied warranty. The information in this document is the proprietary and confidential property of Ember Corporation and is privileged. No part of the drawing or information may be duplicated or otherwise used without the express permission of Ember.

<b>ember</b>		
Ember Corporation 25 Thompson Place Boston MA 02210		
Title: EM900 ATmega128L Breakout Power: RS232_Misc		
Size:	Document:	Rev:
	SCH4473	A1

### EM260 Module Interface

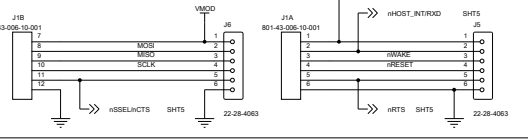

### AVR JTAG

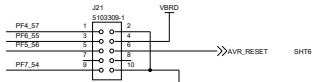

### AVR Programmer

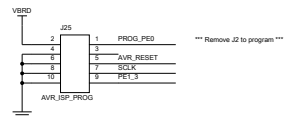

### EM260 RESET

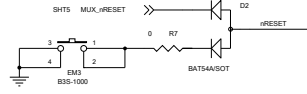

### AVR RESET

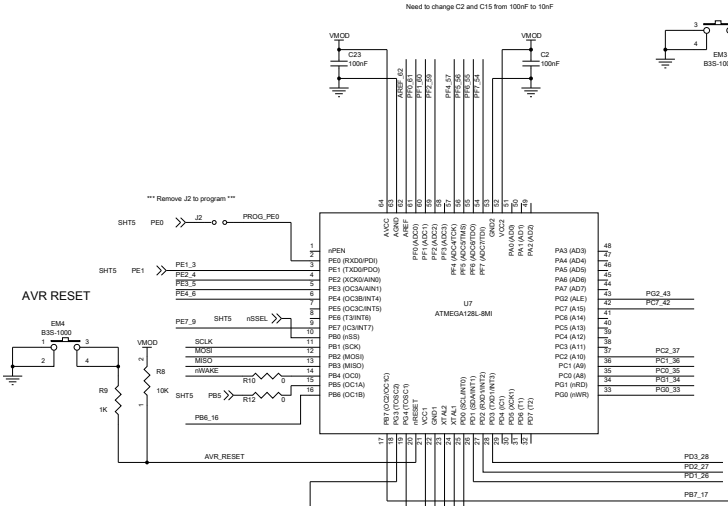

### Temperature Sensor

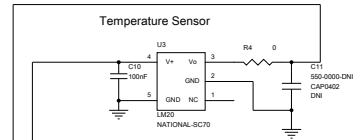

### Application LEDs

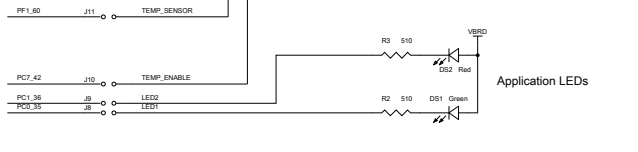

### Application Buttons

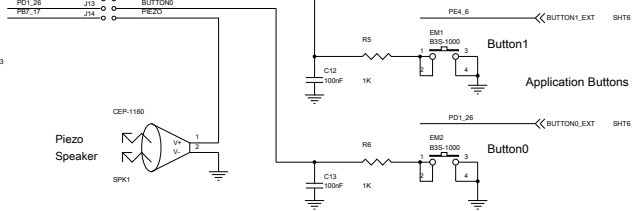

### HOST BOOTLOAD

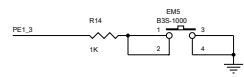

**Disclaimer**  
 The information in this document is subject to change without notice. The statements, configurations, technical data and recommendations in this document are believed to be accurate and reliable, but are presented without express or implied warranty. The information in this document is the proprietary and confidential property of Ember Corporation and is privileged. No part of the drawing or information may be duplicated or otherwise used without the express permission of Ember.

<b>ember</b>	
Ember Corporation 26 Thomson Place Boston MA 02210	
File:	EM260 ATmega128L Breakout
AVR:	Atmega128
Doc:	SCH0473
Rev:	A1

## SIGNAL FLOW DIAGRAM

## OPERATION SELECTION MATRIX

SELECTION	SW1	SW2	Remove Jumpers
SPI MODE ENABLED, USB OUTPUT	1	0	J31
SPI MODE ENABLED, DEI OUTPUT	1	1	J15, J19, J31
SPI MODE ENABLED, TTL ACCESS	1	1	J15, J19, J20, J31, J35
UART MODE ENABLED, USB OUTPUT	0	0	None
UART MODE ENABLED, DEI OUTPUT	0	1	J15, J19 (unsupported)
UART MODE ENABLED, TTL ACCESS	0	1	J15, J19, J20, J35

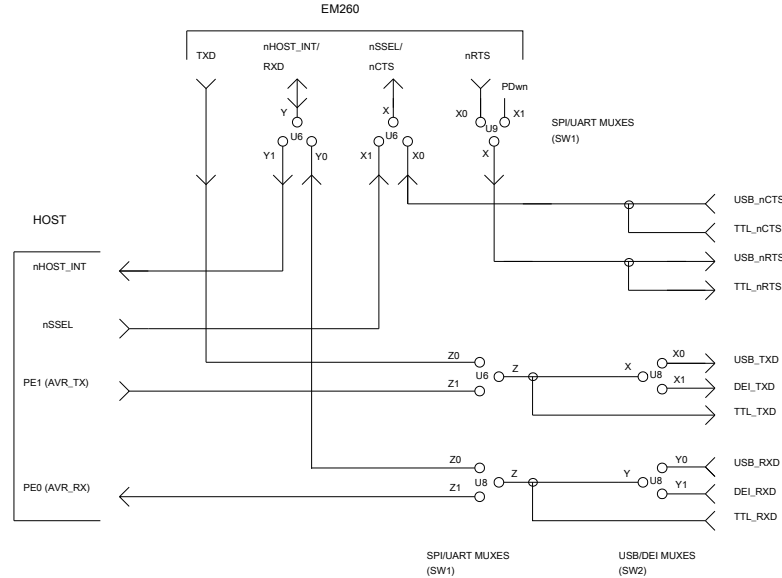

### Disclaimer

The information in this document is subject to change without notice. The statements, configurations, technical data and recommendations in this document are believed to be accurate and reliable, but are presented without express or implied warranty. The information in this document is the proprietary and confidential property of Ember Corporation and is privileged. No part of the drawing or information may be duplicated or otherwise used without the express permission of Ember.

Date: Monday, October 08, 2008

**ember**

Ember Corporation  
25 Thompson Place  
Boston MA 02210

File  
EM260-Alt+regg1231\_Rev001  
Signal Flow Diagram

Size Document Rev  
1 10240473 A1

Sheet 4 of 6

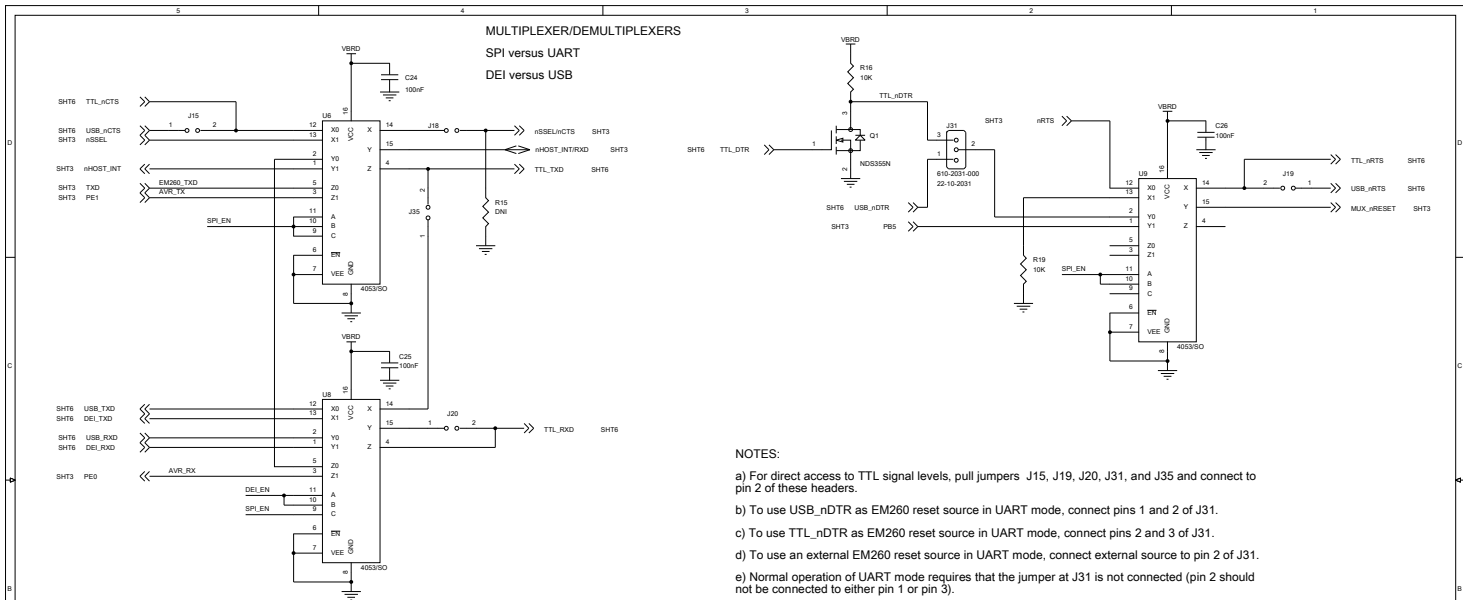

**NOTES:**

- For direct access to TTL signal levels, pull jumpers J15, J19, J20, J31, and J35 and connect to pin 2 of these headers.
- To use USB\_nDTR as EM260 reset source in UART mode, connect pins 1 and 2 of J31.
- To use TTL\_nDTR as EM260 reset source in UART mode, connect pins 2 and 3 of J31.
- To use an external EM260 reset source in UART mode, connect external source to pin 2 of J31.
- Normal operation of UART mode requires that the jumper at J31 is not connected (pin 2 should not be connected to either pin 1 or pin 3).

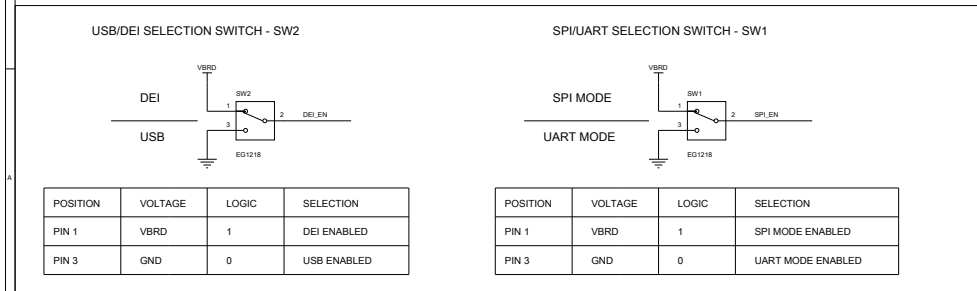

Disclaimer

The information in this document is subject to change without notice. The statements, configurations, technical data and recommendations in this document are believed to be accurate and reliable, but are presented without express or implied warranty. The information in this document is the proprietary and confidential property of Ember Corporation and is privileged. No part of the drawing or information may be duplicated or otherwise used without the express permission of Ember.

Ember Corporation  
25 Thorton Place  
Boston MA 02210

File: CH050-Alt+reg2-DEI-Blockout  
SPLIUART & USB/DEI LOGIC

Size	Document	Rev
1	IC040473	A1

Date: Thursday, May 29, 2008 Sheet: 5 of 6



Copyright © 2008-2012 by Ember Corporation

All rights reserved. Neither this publication nor any part thereof can be copied, photocopied, reproduced, translated, or converted to any electronic or machine-readable form in whole or in part without prior written approval of Ember Corporation. This documentation is furnished under license and can be used or copied only in accordance with the terms of such license.

The content of this documentation is furnished for informational use only, is subject to change without notice, and does not represent a commitment or guaranty by Ember Corporation. The statements, configurations, technical data, and recommendations in this document are believed to be accurate and reliable as of the time of publication, but Ember Corporation assumes no responsibility or liability for any errors or inaccuracies that may appear in this documentation. DOCUMENTATION IS PROVIDED "AS IS" AND ALL EXPRESS OR IMPLIED CONDITIONS, REPRESENTATIONS AND WARRANTIES, INCLUDING ANY IMPLIED WARRANTY OF MERCHANTABILITY, FITNESS FOR A PARTICULAR PURPOSE OR NONINFRINGEMENT, ARE DISCLAIMED. Users are responsible for their applications and for the use of any products specified in this document.

Title, ownership, and all rights in copyrights, patents, trademarks, and other intellectual property rights embodied in Ember Corporation's Products and any copy, portion, or modification thereof, shall not transfer to Purchaser or its customers and shall remain in Ember Corporation and its licensors.

No source code rights are granted to Purchaser or its customers with respect to any Ember software. Purchaser agrees not to copy, modify, alter, translate, decompile, disassemble, or reverse engineer Ember hardware (including without limitation any embedded software) or attempt to disable any security devices or codes incorporated in Ember hardware. Purchaser shall not alter, remove, or obscure any printed or displayed legal notices contained on or in Ember hardware.

Ember is a trademark of Ember Corporation. All other trademarks are the property of their respective holders.

